

Number Explorer Missions



**Count down from 3 to start a race.
3, 2, 1, 0!**



**Count down from 5 to 0 as
you tidy away 5 toys.**



**Hold up 1 hand and put down 5
fingers. How many fingers are left?**



Play Together

Zero the hero! Look out for opportunities to count down from 5 to zero together! You could do this as you tidy away toys, as you munch small snacks or to tick away the final seconds before bed. You can count up from zero too!

For your next mission, find the episode 'Six'

Zero

This mission belongs to

I'm Zero,
the hero!



Fact File

Zero means nothing,
none, not even !!



Zero has 0 blocks,
that's no blocks at all!

Zero is 1 less than One.

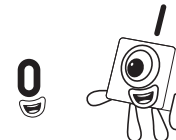

Numbers to 5



Meet Zero



Zero

Activities

Who is it?

Which Numberblock is 1 less than Three? Tick them.

Which Numberblock is 1 less than Two?

Which Numberblock is 1 less than One?

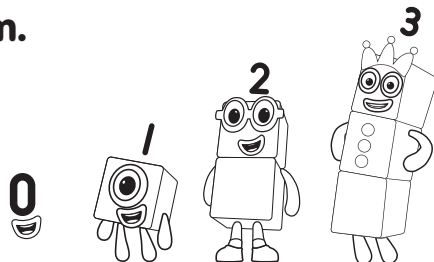

Spot it!

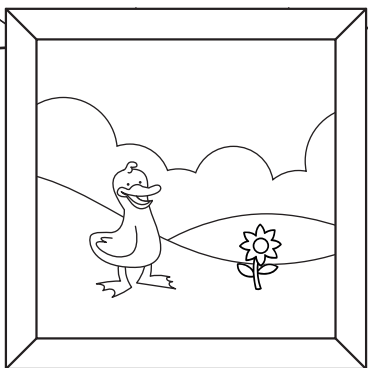

How many trees are in the picture?

How many cats?

How many boats?



Circle the plant pot with 0 flowers.

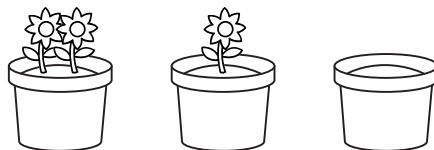

Draw it!

Write in the missing number!



5, 4, 3, 2, 1, 0!

Cut out the bunches of leaves and use them to make the birds disappear until there are zero!

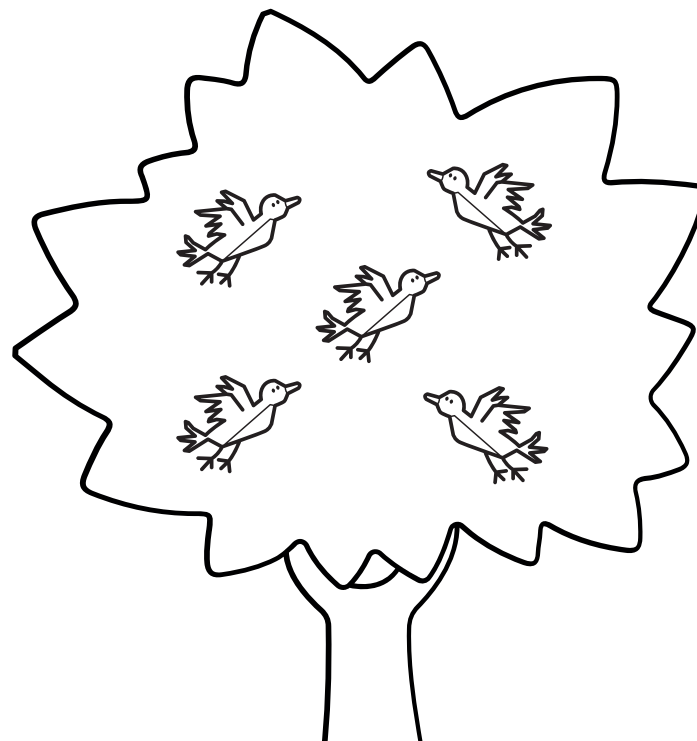

5, 4, 3, 2, 1, 0!

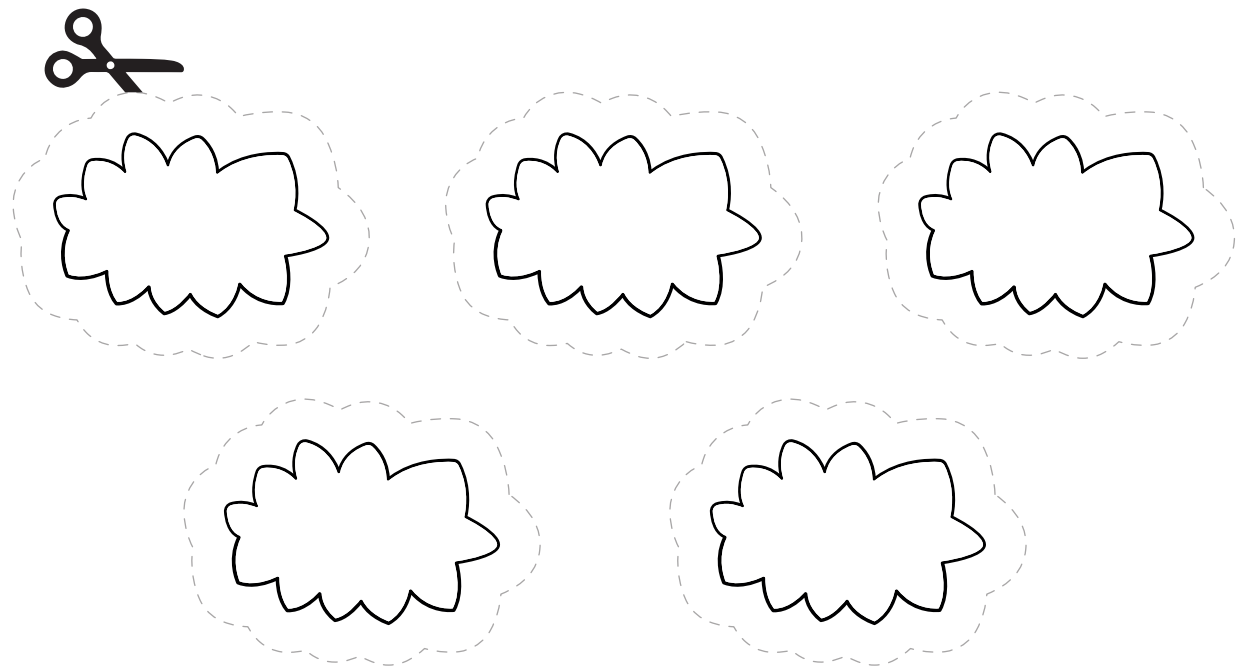

Number Explorer Missions



Hold up 3 fingers,
then clap 3 times



Collect 3 leaves when you are outside



Find 3 toys to play with



Climb up 3 steps – 1, 2, 3
Then down again – 3, 2, 1



Play Together

Play Three's Shapes Game!

Cut out the 3 x 3 grid and the three squares of paper (your little learner could colour these before you play).

How many ways can they find to fit the 3 squares into the grid so that all the squares are touching? Can they copy the shapes in Three's Fact File on the first page?

Find the episode 'One, Two, Three' for your next mission!

Three

This mission belongs to _____

3

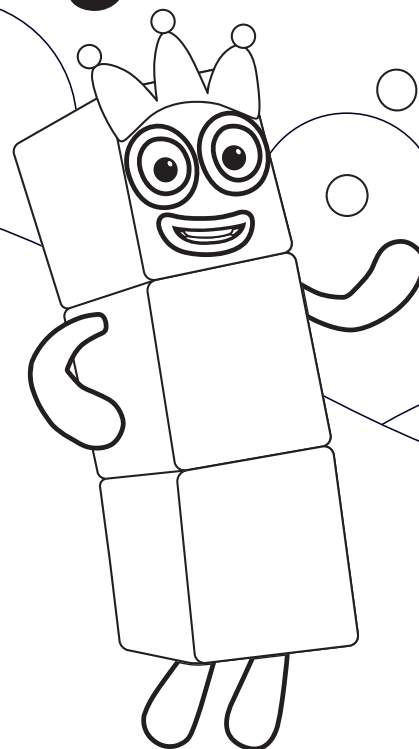

Fact File

3 is this many:



Numberblock Three
has 3 blocks:



Three can make
these shapes:

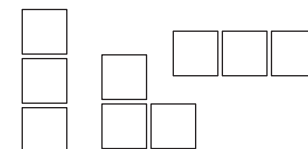

Numbers to 5



Meet Three



Three

Activities

2

Touch and Count!

Touch each Numberblock and say their name!

Start with me!

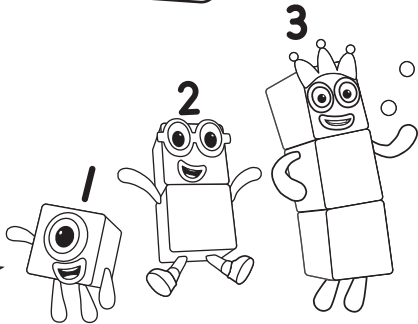

Who is it?

Which Numberblock is 1 more than One? Point to them.

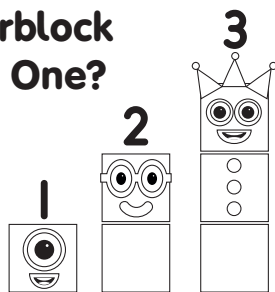

Which Numberblock is one more than Two? Say their name.

Count and tick

Tick the plates that have 3 fruits.

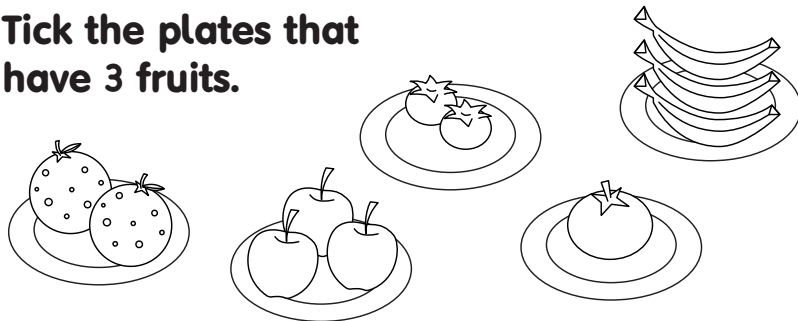

Spot it

Find all the number 3s and circle them.

3

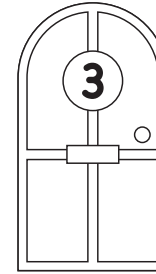

Draw 3 lines to make a triangle around Three.

Shape fun

Can you draw more triangles?

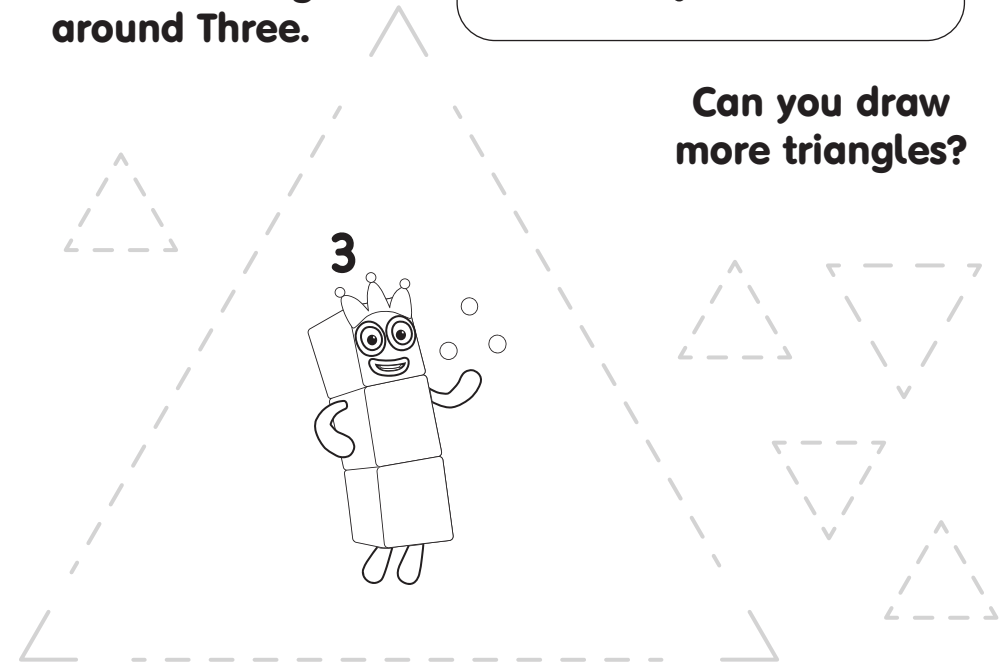

Three's Shapes Game



| | | |
|--|--|--|
| | | |
| | | |
| | | |

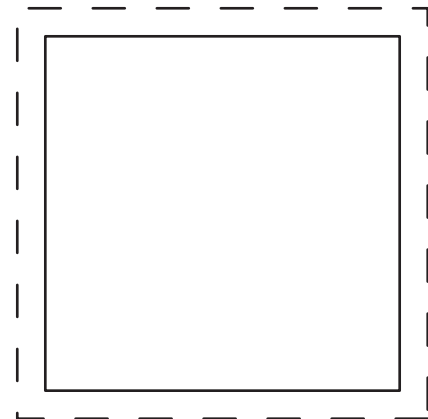
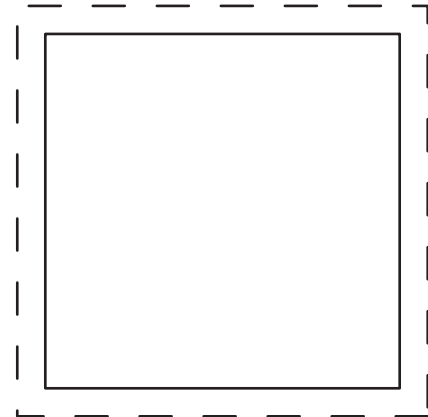
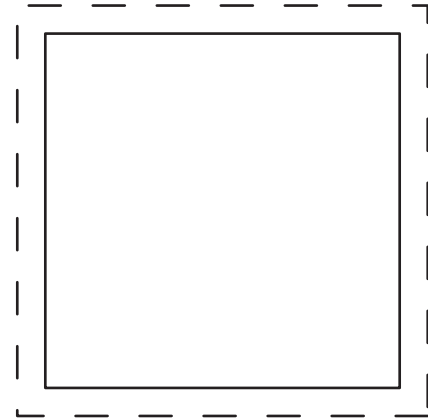

Number Explorer Missions



Can you stack 3 cushions on top of each other?



Find 2 things that make a pair



Draw 1 big circle in the air



Spot 3 buses – 1, 2, 3!



Play Together

Fun with 1, 2, 3. Cut out the Numberblocks to play with. Explore all the ways to make 3 - with 1 Three, 3 Ones, Two plus One or One plus Two. The number stack can help your little learner to see the difference between numbers, e.g. stand Numberblock Two on it to see that he needs 1 more to make 3.

For your next mission, find the episode 'Four'

One, Two, Three

This mission belongs to _____

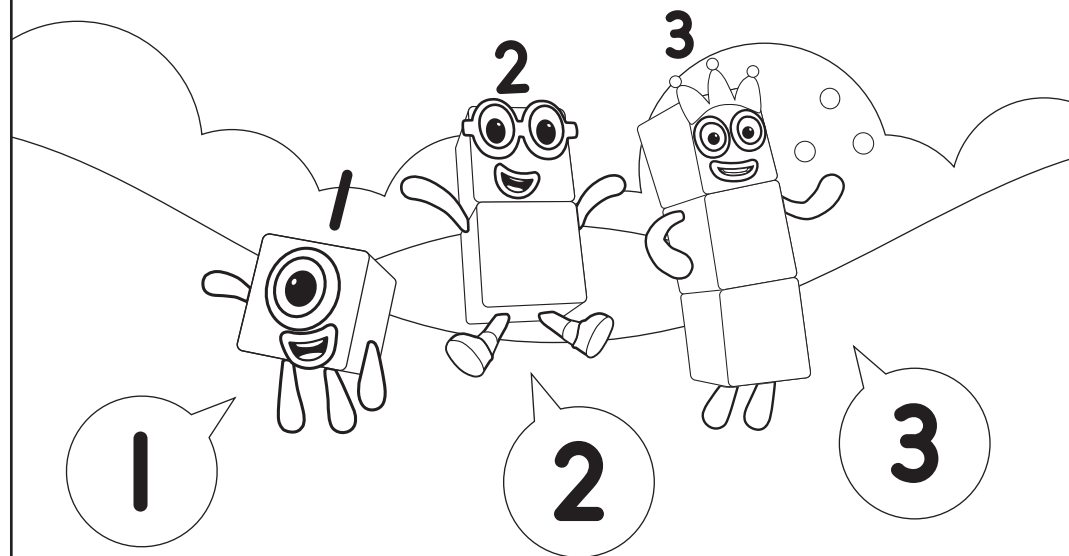

Say the numbers with the
Numberblocks!

Point to the smallest number!

Who is the biggest?



Numbers to 5



Compare 1, 2 and 3



One, Two, Three

1 2 3 Activities 1 2 3

Spot it

Can you find 1, 2, 3 little rabbits hiding on this double page?



Who is it?

Someone is missing!
Can you draw in the missing Numberblock?

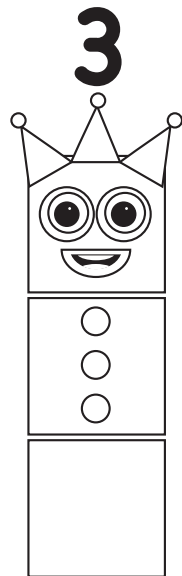
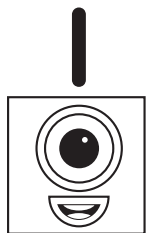

Draw a line to match each Numberblock to the right tree.

Match up

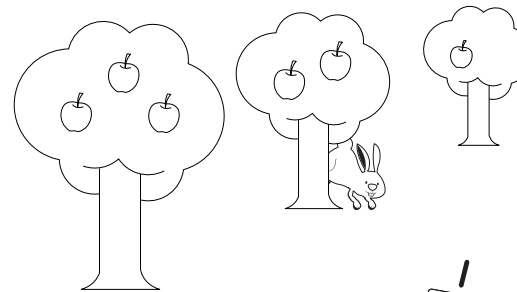

My tree is the smallest!

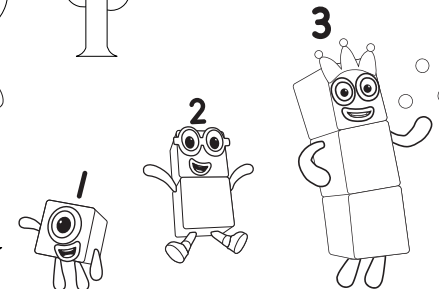

Number Magic

What number do 1 and 2 make together?



Say the number!



1, 2, 3

Which row of Numberblocks is in the right order? Tick them.

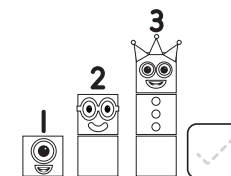
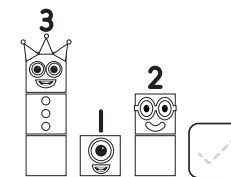

Fun with 1, 2, 3

3

2

1

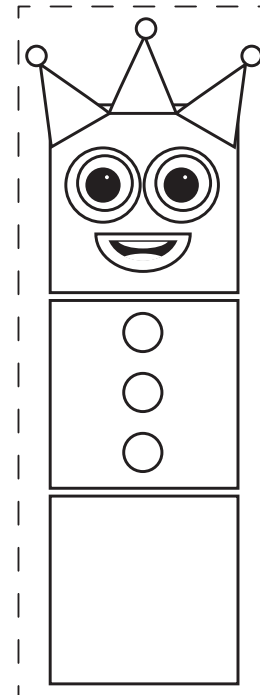
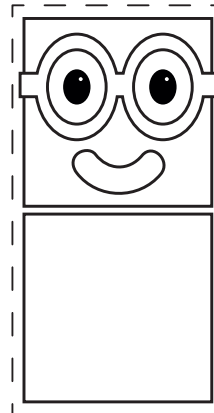
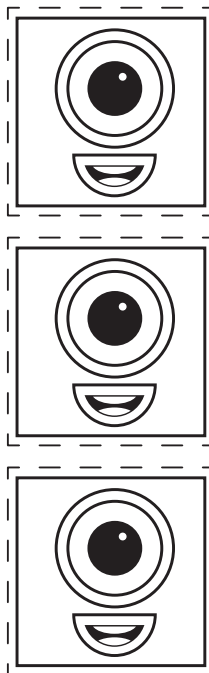
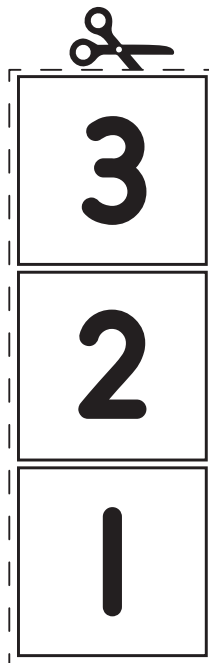

Number Explorer

Missions



Hold up 2 fingers on each hand.
How many fingers can you see?



Do 4 big jumps



Find a number 4



Count how many arms and legs you have



Play Together

Go 4 spotting! When you are out and about, or even around the house, look out for 4s and things that come in 4s. You can look for the number on signs, doors, or count the wheels on cars, the legs on tables, the sides on a square or rectangle shape, the screws on a panel and lots more.

For your next mission, find the episode 'Five'

Four

This mission belongs to _____

Fact File

4 is this many:



Numberblock Four
has 4 blocks:



Four can make a square shape, like this:

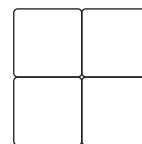

I love squares!

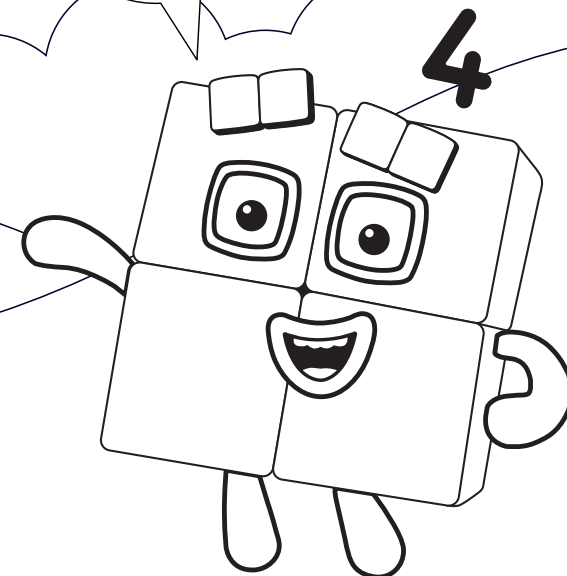

Numbers to 5



Meet Four



Four

Activities

Spot it!

Circle all the number 4s.

4 2 4
3 4 3 1 4 3



Count and draw

Draw 4 lines to finish the square.

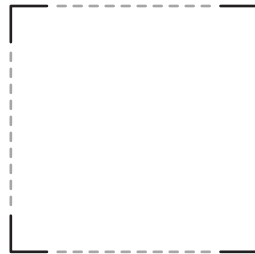

Now draw 4 corners.



Shape Fun

Which shadow belongs to 4?
Circle it.

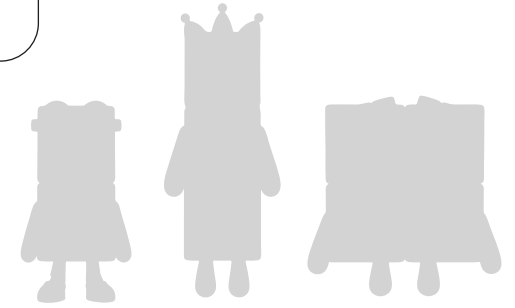

Tick the pictures that have 4 things.

Count and tick

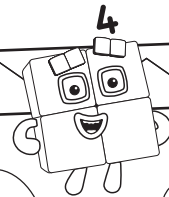
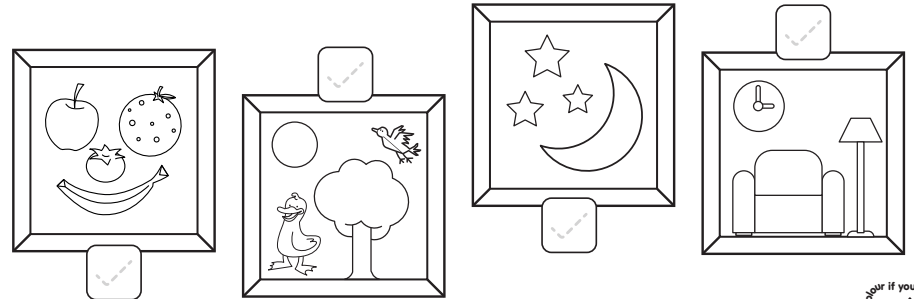

Draw it

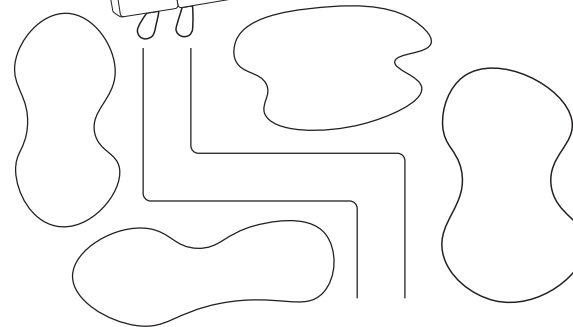

Draw a path to help Four wiggle past four puddles.



Number Explorer Missions

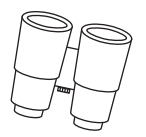

Count the fingers on one hand



Shout all the numbers from 1 to 5!



Tap your foot 5 times



Do 5 star jumps!



Play Together

Fun with Five. Draw around your hands and feet, then cut them out and count the fingers or toes! Try folding down a finger (or two) - how many are left? What if you fold down 4 toes? Can you explore all the ways to make five? Pin the finished hand or foot shapes to the walls, use them to make a trail to follow, or hang them up with string.

For your next mission, find the episode 'Three Little Pigs'

Five

This mission belongs to _____

High five!

5

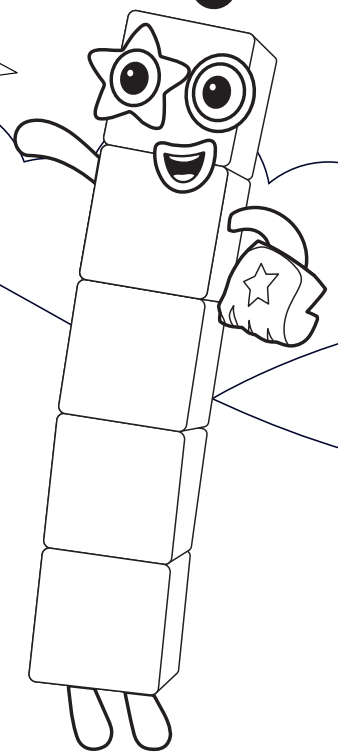

Fact File

5 is this many:



Numberblock Five has 5 blocks:

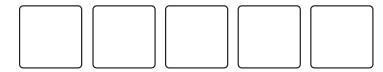

Five can make all these shapes:

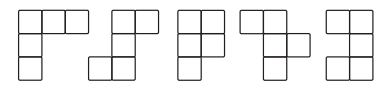

Print pages 1 and 2 double-sided and fold in half to make a booklet



Numbers to 5



Meet Five



Five

Activities

Spot it!

Which one is Five's numberingling?
Circle it.

2 1 5 3 4

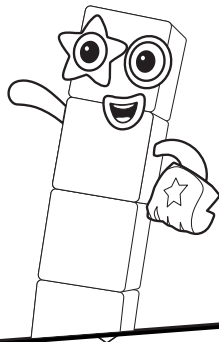

Let's count

Touch each finger and count to 5!

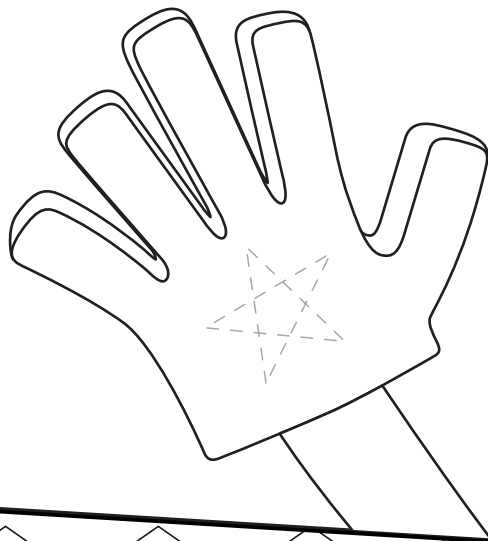

Draw 5 lines to finish the star for Five.



Making 5

Which Numberblocks can make 5 together?
Draw lines to match them.

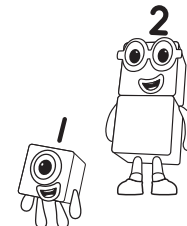
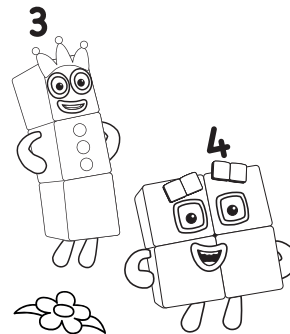

Spot it!

Can you find 5 flowers on this page?



Who is it?

Which Numberblock is 1 less than Five?
Say their name.

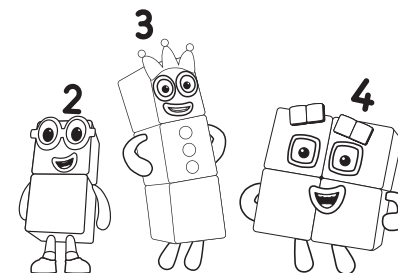

Number Explorer Missions

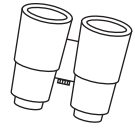

Can you spot a house with 1 door?



Look for a house with 4 windows



Can you see 3 trees?



Find a door with a 2 on it



Play Together

Tell the story. Cut out the Numberblocks and have fun acting out the story of the Three Little Pigs. Who will be the Big Bad Square and try to blow their houses down?

For your next mission, find the episode 'Off We Go'

Three Little Pigs

This mission belongs to _____

Which Numberblocks can you see?
Say their names!

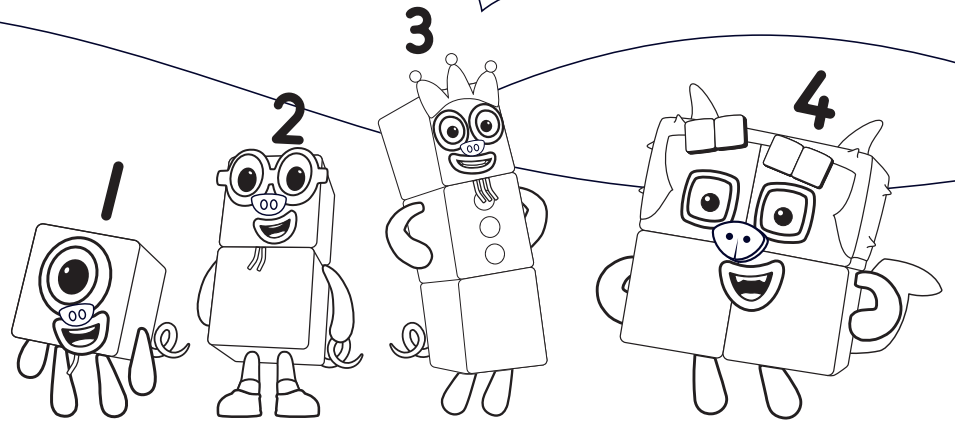

Can you see who are the pigs and who is the wolf?



Numbers to 5



Numbers are made of 1s



Three Little Pigs

Print pages 1 and 2 double-sided and fold in half to make a booklet

Draw and count

2

Can you finish the houses for One, Two, Three and Four?

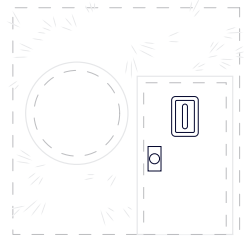

One door!

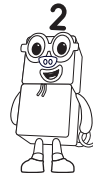

Two windows!

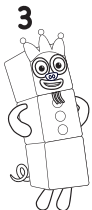
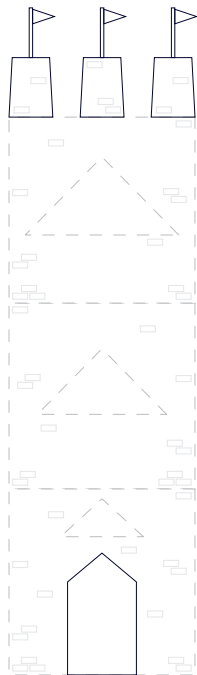

Three floors!

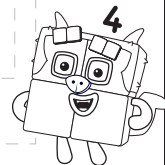
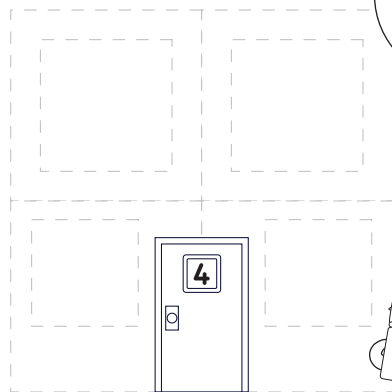

A four on the door!



Match up

3

The Ones are making bigger numbers. Can you match each row of ones with the numberblock they make?

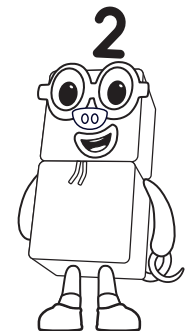
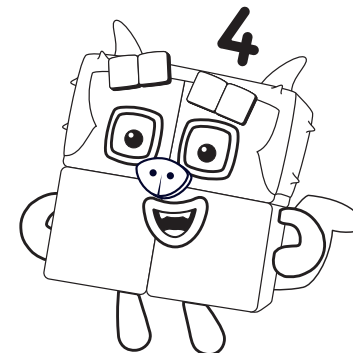
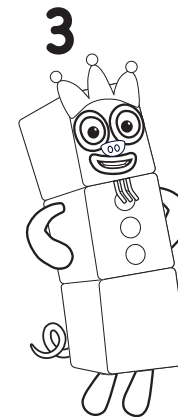
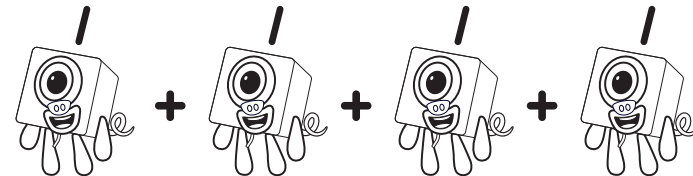
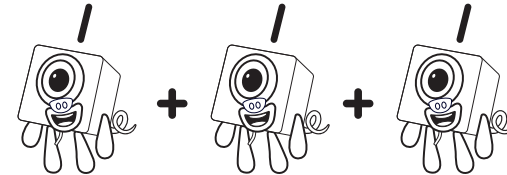
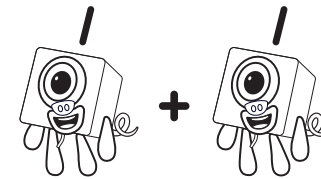

Tell the story

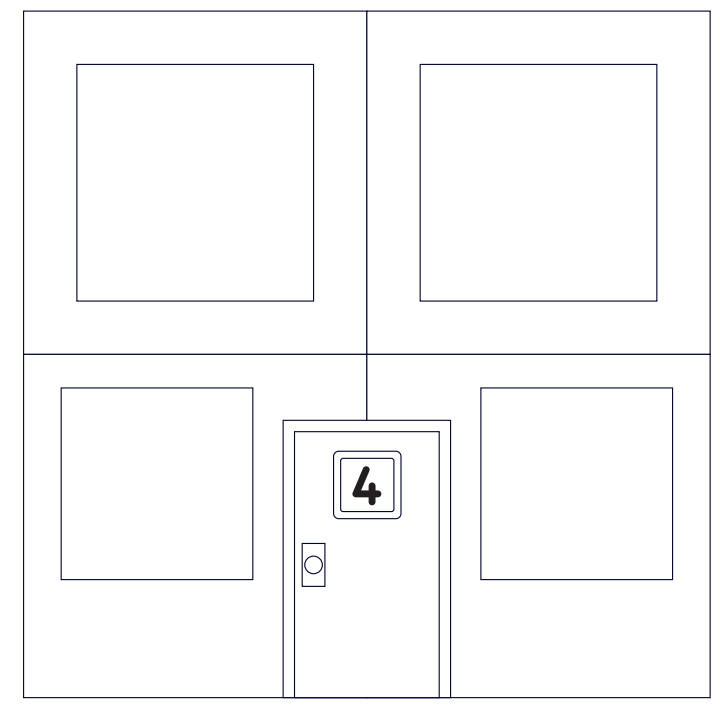
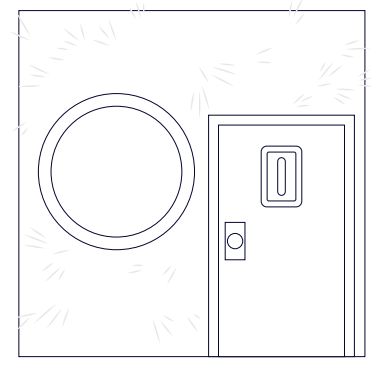
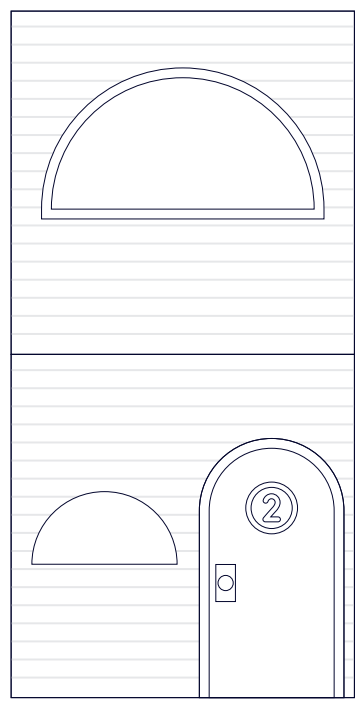
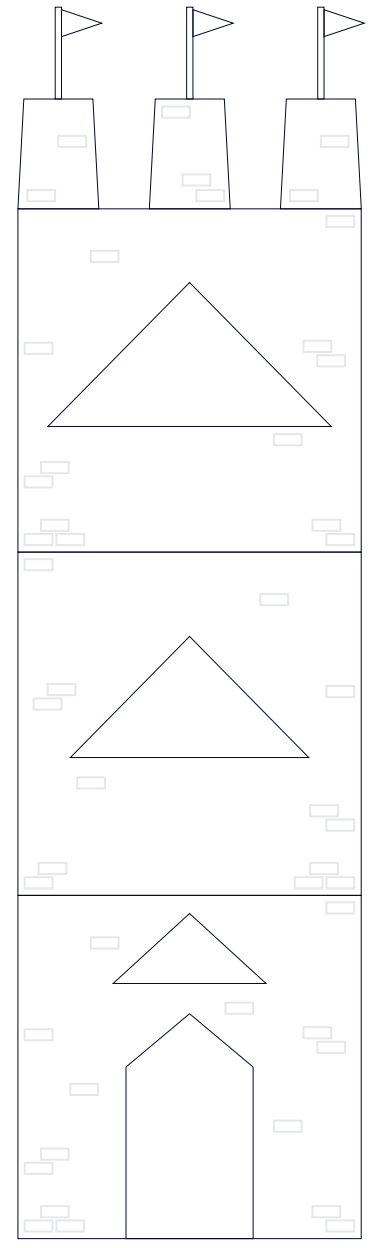
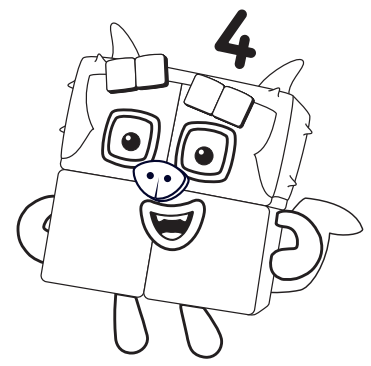
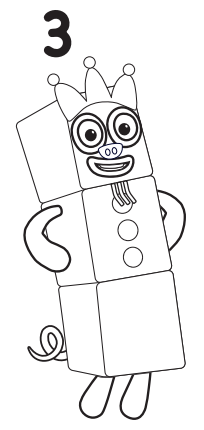
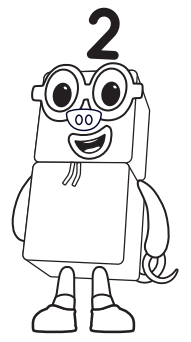
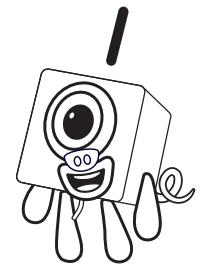

Number Explorer Missions



Spot a 1 when you are out and about



Find something that comes
in a pair for Two



Hop on the spot 3 times



Do 5 star jumps! High Five!



Play Together

Colouring fun! If you and your little learner have been working on these missions, you deserve a treat! Why not take some time to colour the poster together? You could use 5 different colours - red for One, orange for Two, yellow for Three, green for Four and blue for Five.

For your next mission, find the episode 'Blockzilla'

Once Upon a Time

This mission belongs to

Which Numberblocks is this book about?
Say their names.

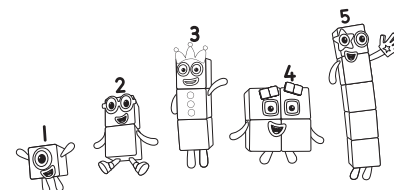

Numbers to 5



All about 1 to 5



Once Upon a Time

Activities

2

Draw and count

Draw 1 fun thing for
Numberblock
One.

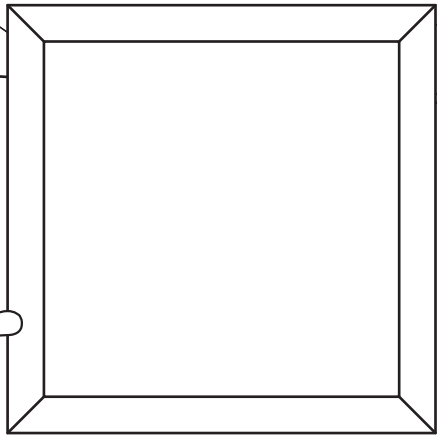
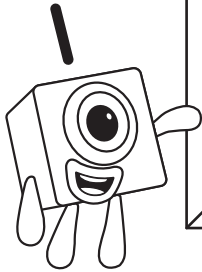

Two together

March around
like Two and
say 1,2, 1, 2!

1, 2! 1, 2!

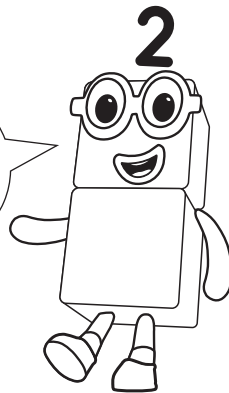

Count and circle

Count Three's
buttons and
circle them.

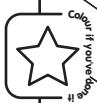
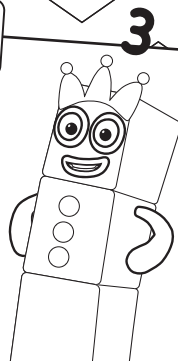

Let's draw!

3

Draw a big square
for Numberblock
Four and Squarey.

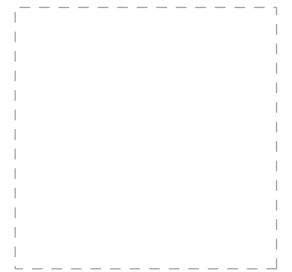
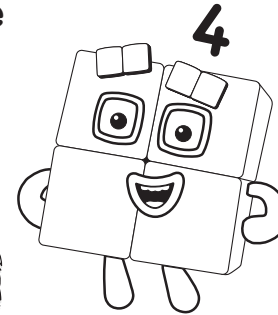

Let's count!

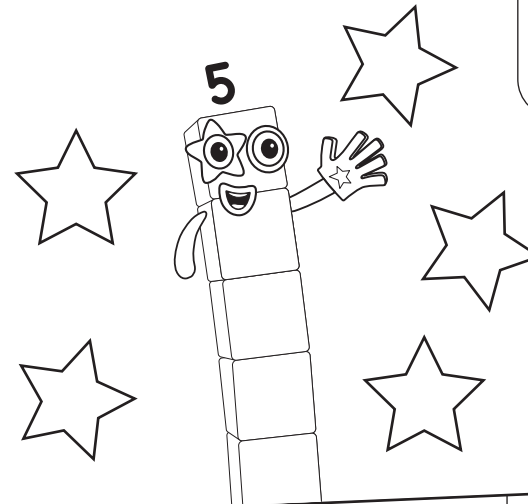

Five loves stars.
How many stars
has she found?
Say the number.



Match up!

5 2 1 4

Draw lines to match
each Numberblock
to their numberling.

3

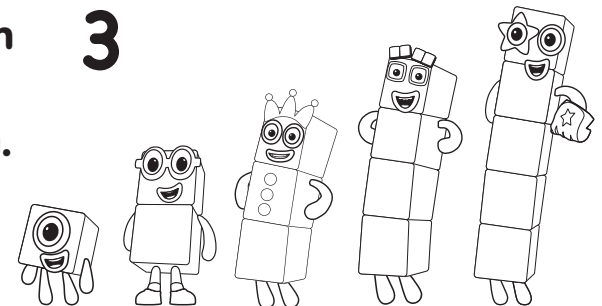

I can count to 5!

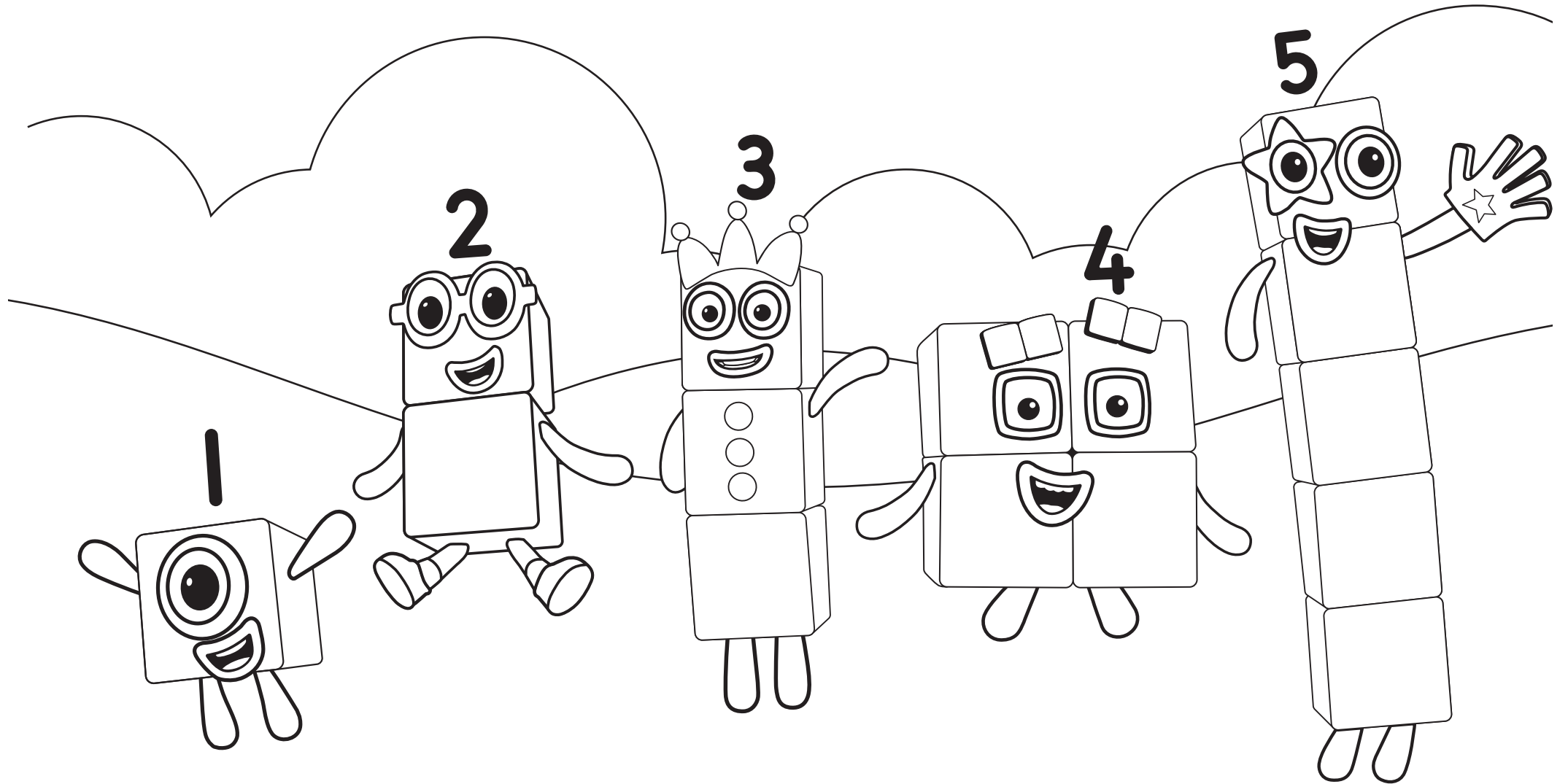

Number Explorer Missions



Draw a train with 3 parts. How many more parts do you need to get to 5?



Find 4 sticks or pebbles. Can you split them so you are holding the same number in each hand?



Hold up 5 fingers. Fold down two. How many fingers are still up?



Play Together

The Numberblocks Express! Cut out the pieces of the Numberblocks Express. Say a number and ask your child to show you a way to make that number with their Numberblocks and the plus or minus signs. When they have made the number (or you've helped them get it right) they get a piece of the Numberblocks Express. Can they build the whole train?

For your next mission, find the episode 'Fruit Salad'

The Numberblock Express

This mission belongs to

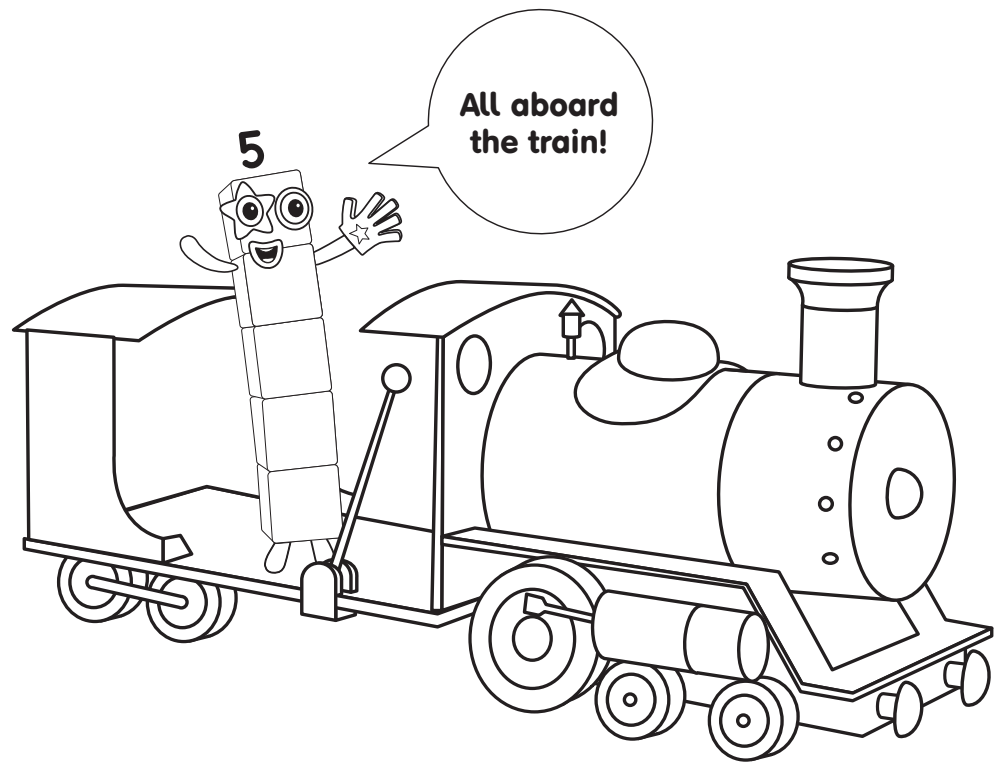

Numbers to 5



Add and subtract to 5



The Numberblocks Express

Print pages 1 and 2 double-sided and fold in half to make a booklet

Who is it?

2

Can you find the missing Numberblocks?

Let's add 1!

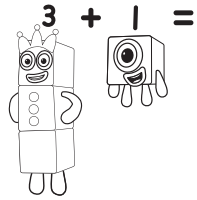
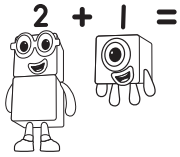
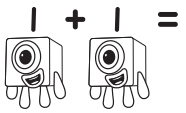

Let's add 2!

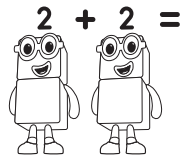
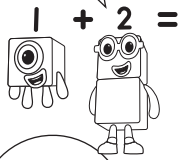
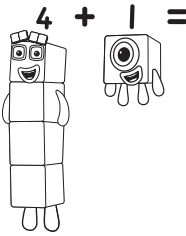

Let's add 3!

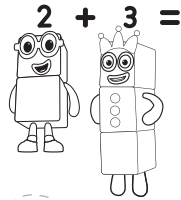
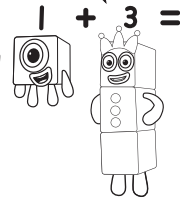
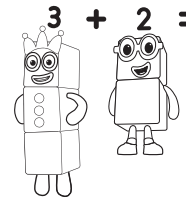

Let's add 4!



Who is it?

3

It's time to take away.

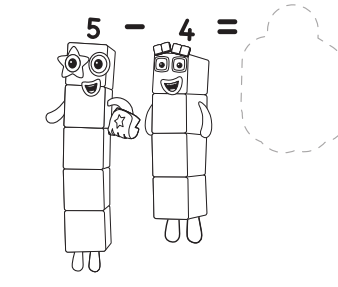
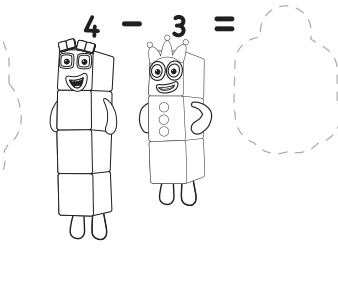
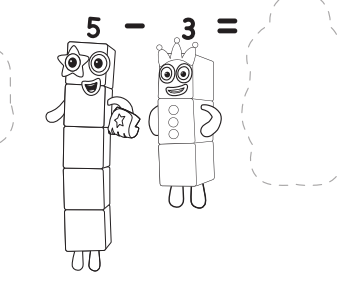
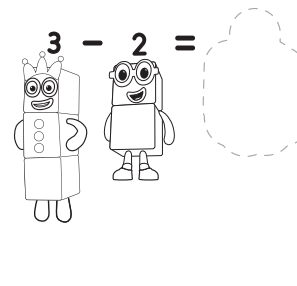
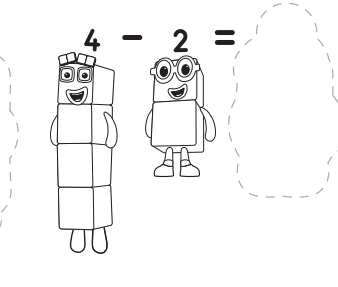
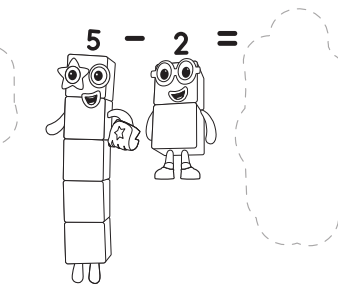
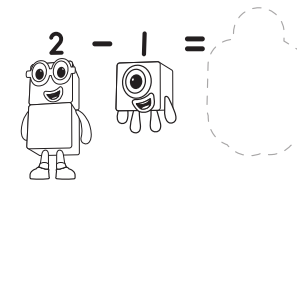
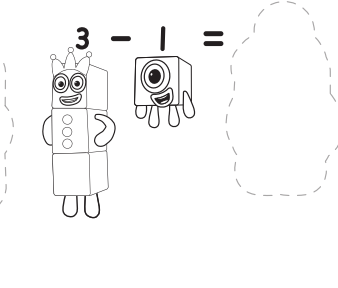
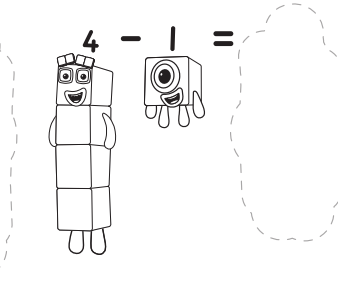
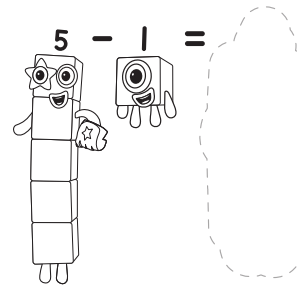

Get ready!

Cut out these Numberblocks and use them to give your answers.

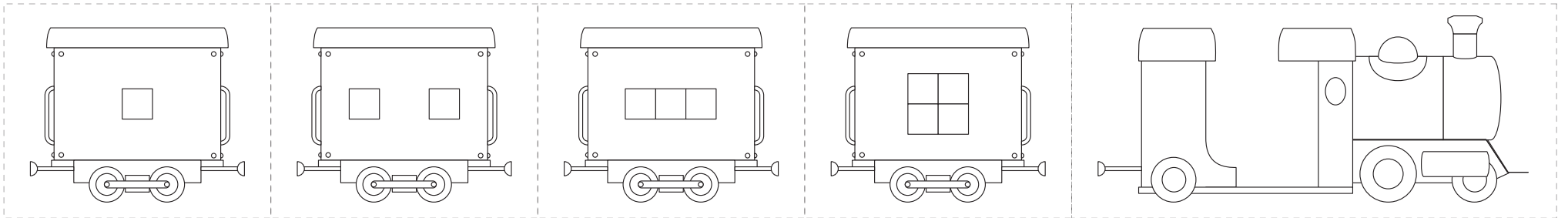
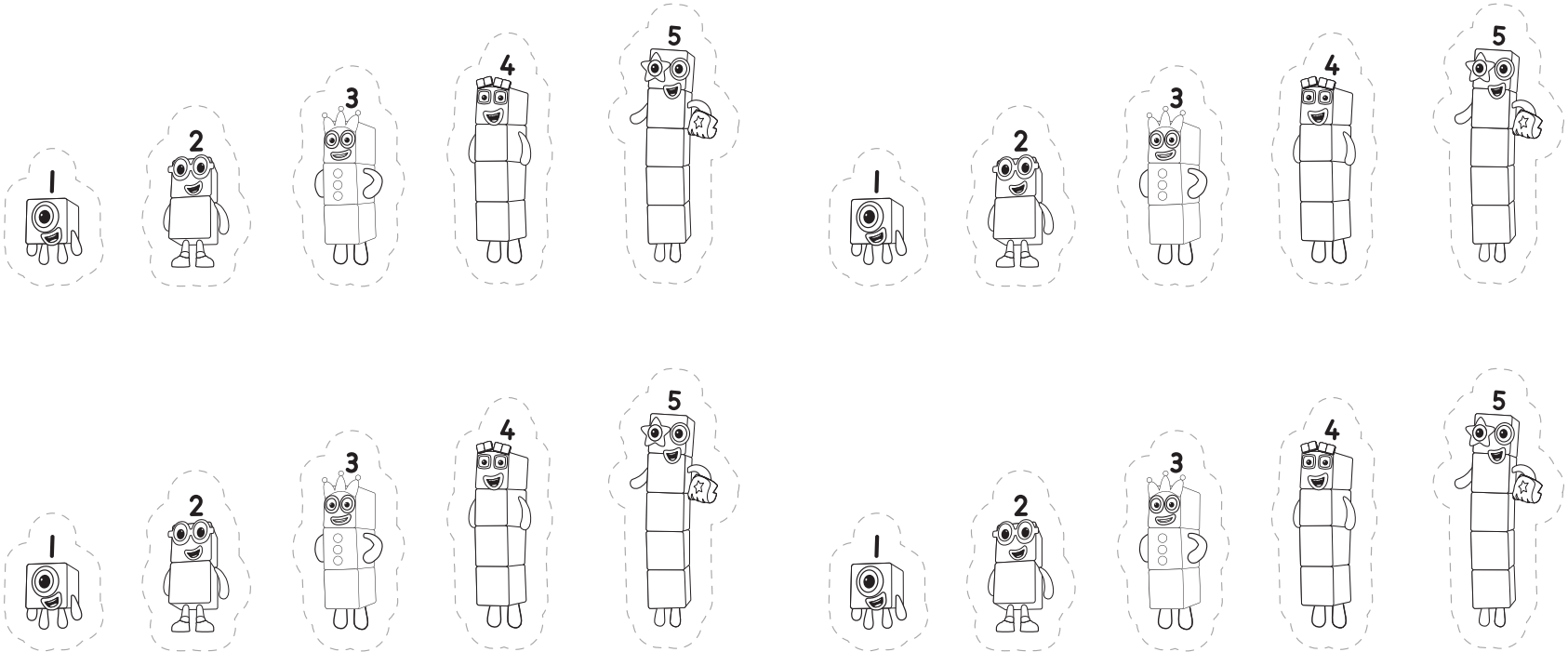

Number Explorer Missions



Hold up 2 fingers on one hand and 3 on the other. How many fingers are you holding up all together?



Find 4 grapes. Then split them evenly into 2 bowls.



Pick up 1 stick in your left hand and 2 sticks in your right hand. How many sticks all together?



Play Together

Fruit Salad! Take turns with your little learner to make and solve your own fruit salads, using bowls or plates and small objects from the house (try to make all your objects the same!)

For your next mission, find the episode 'Zero'

Fruit Salad

This mission belongs to _____

3

Welcome to my fantastic fun fruit factory!

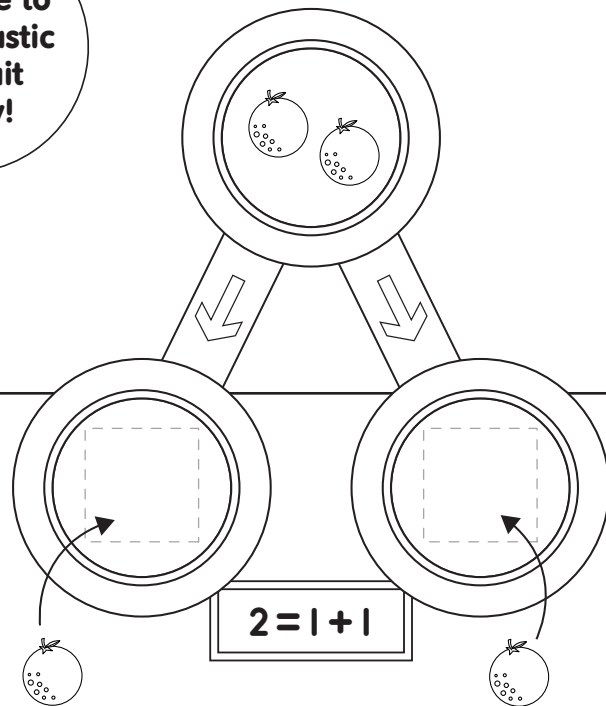
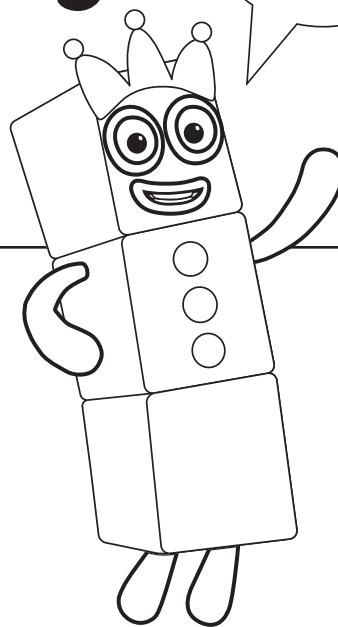

Print pages 1 and 2 double-sided and fold in half to make a booklet



Numbers to 5



Add and subtract to 5



Fruit Salad

Match your fruit to what's in the top of the machine, then split them into the right numbers at the bottom.

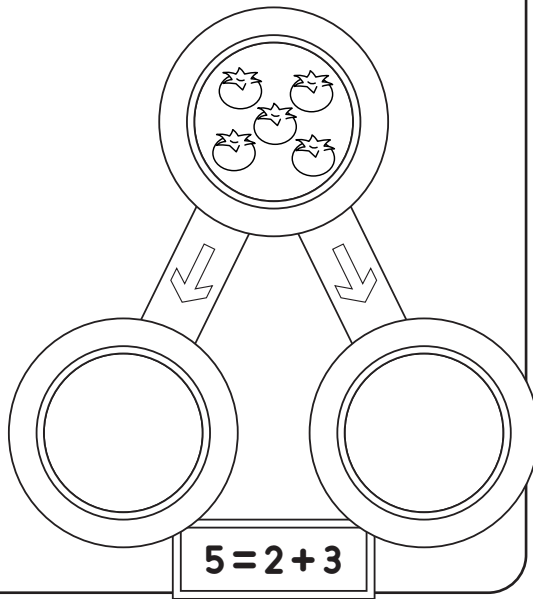
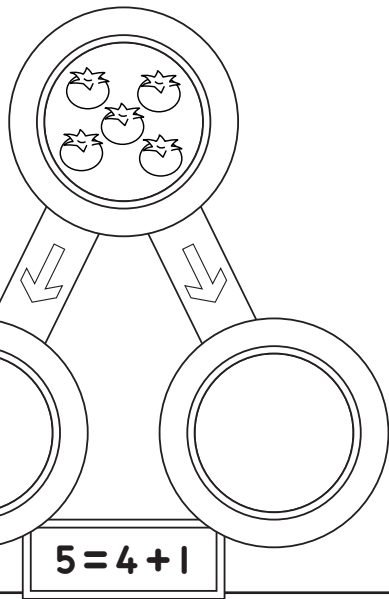
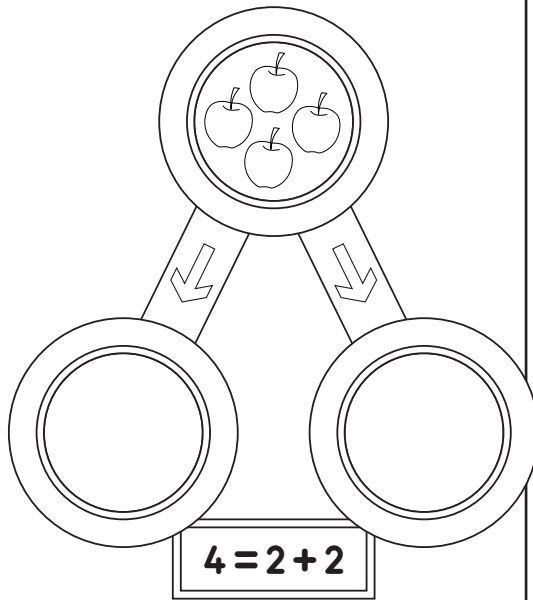
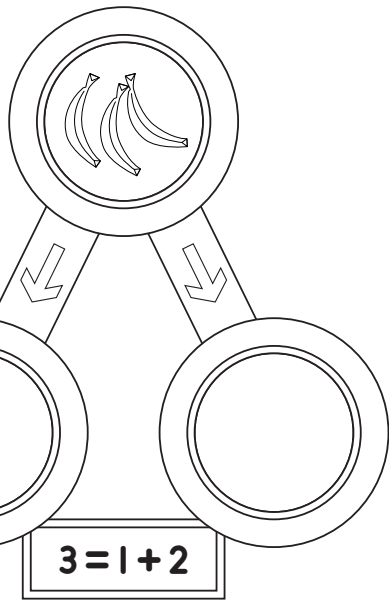

Now match the fruit at the bottom and zoom them to the top to see what they make!

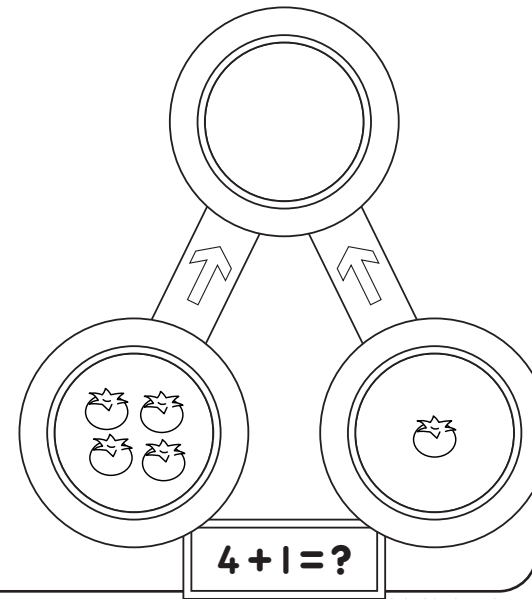
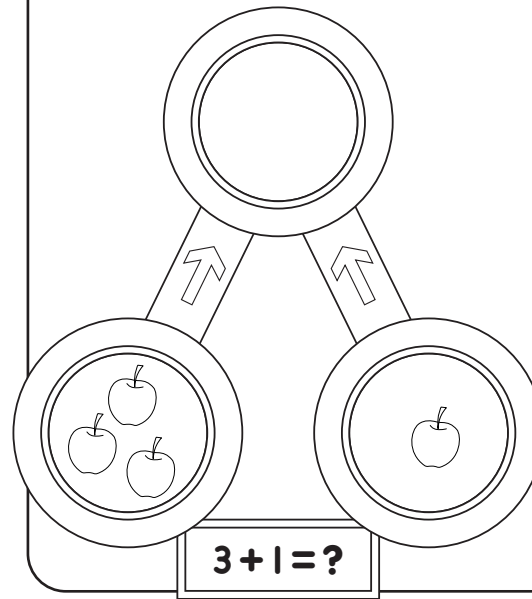
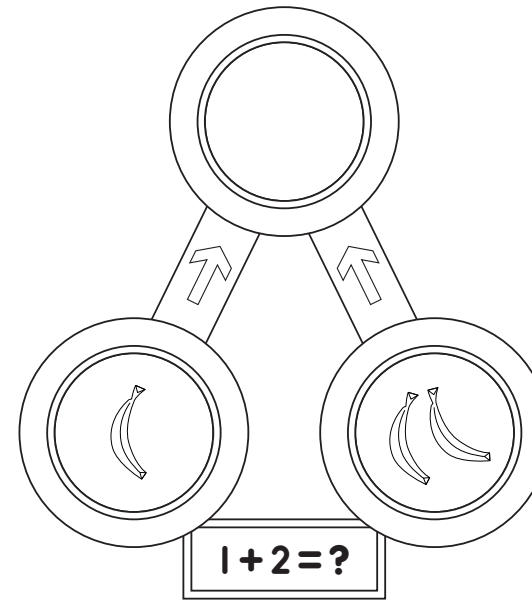
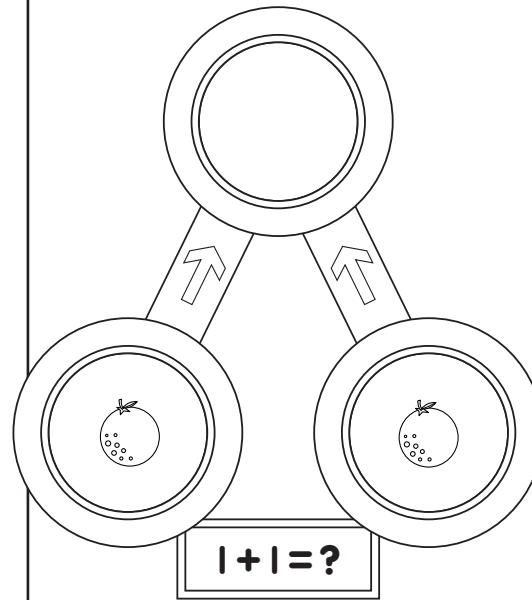

Get ready!

Cut out all the fruit to play Three's game!

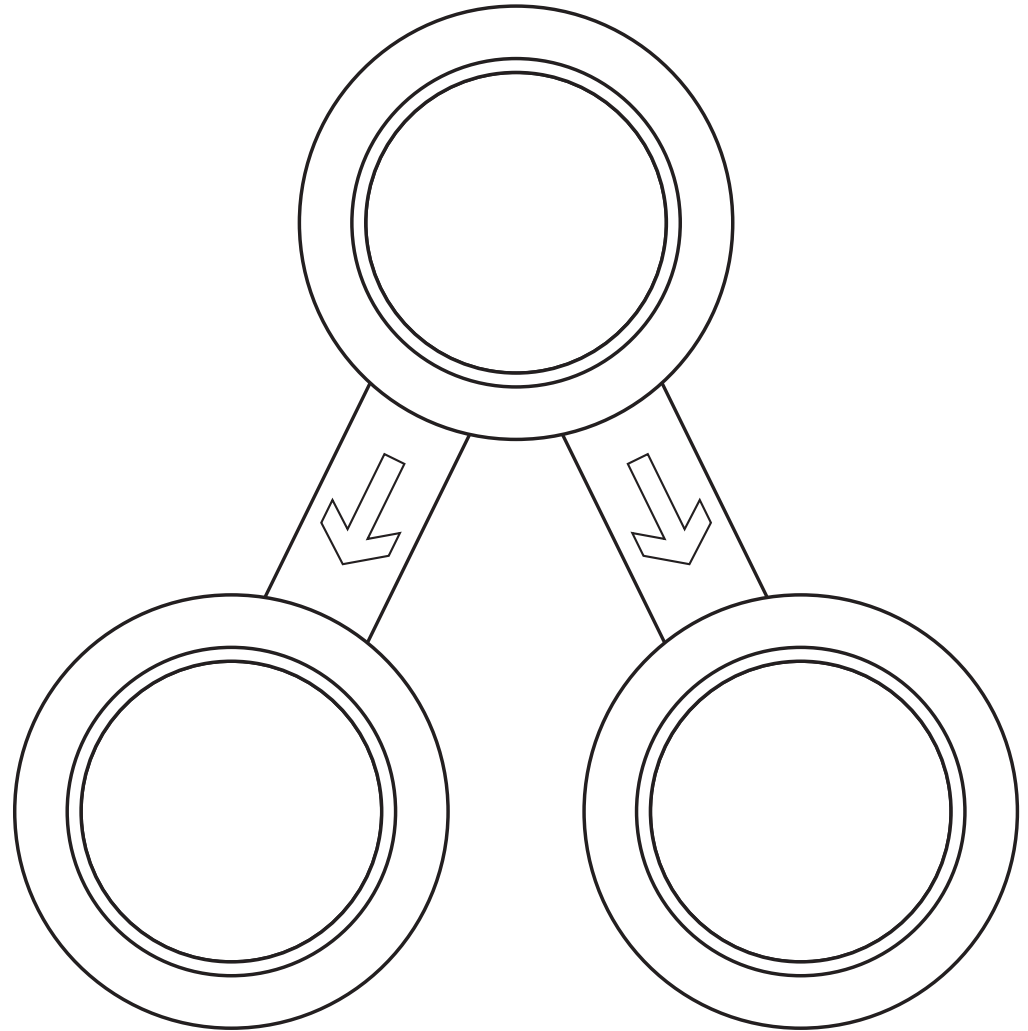
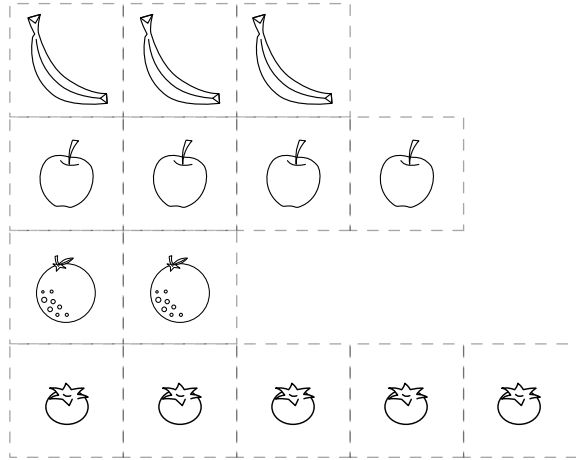

Number Explorer Missions



Count your hands 1, 2. 2 hands!



Count your feet



Count your ears



Find a mirror and count your eyes



Play Together

Add one more! Find some sets of two things - small toys, bananas, cups, balls of paper. With your child, count 1 and then say 'plus one' and add 1 more thing. Say 'makes 2', then count the things. If your child is confident doing this, try taking away one thing, saying 'two take away one makes...?' Ask your child how many are left.

For your next mission, find the episode 'Two'

One More

This mission belongs to _____

Can you draw
1 more One?

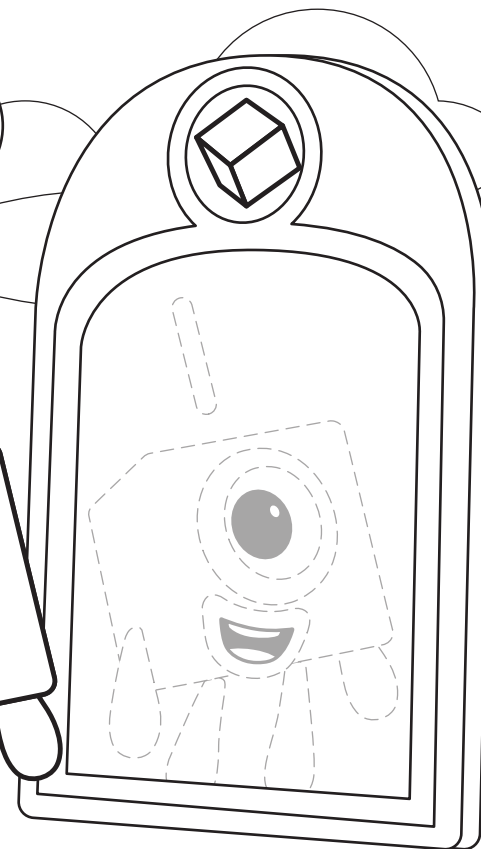
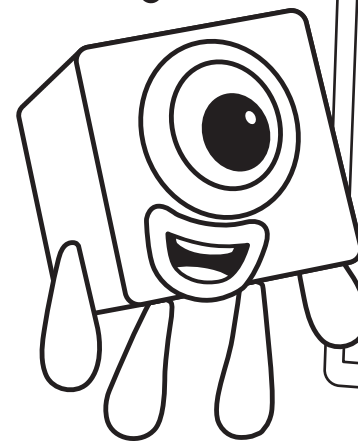

Numbers to 5



Adding 1



Another One

Activities

Draw and count

Draw the arrow to help One jump on top of One!

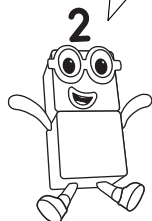
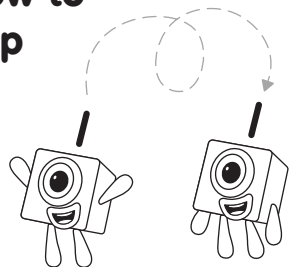

You made 2!



Touch and count

Touch Two's 2 blocks and count them out loud.

Can you count his shoes too?

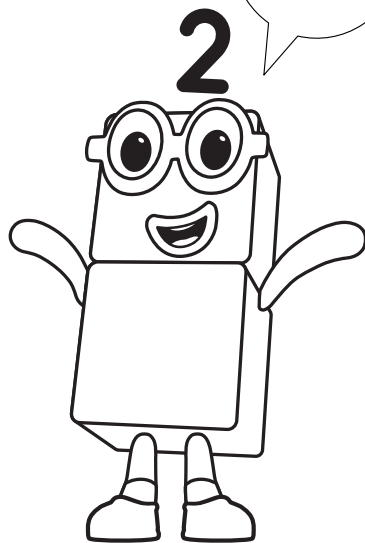

1, 2.
Two!



Who is it?

What does 1 plus 1 make? Circle the Numberblock.

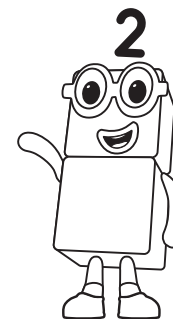
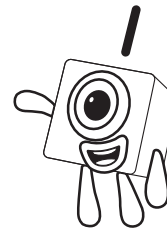

Draw and count

Do another scribble to make 2 scribbles!

Now do 2 scribbles here.

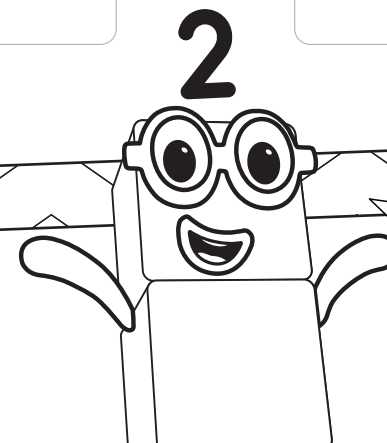
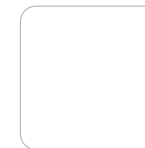
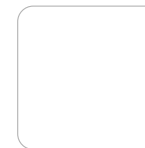
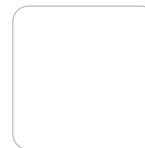

I'm one more than one!



$1+1=2$

$1+1=2$

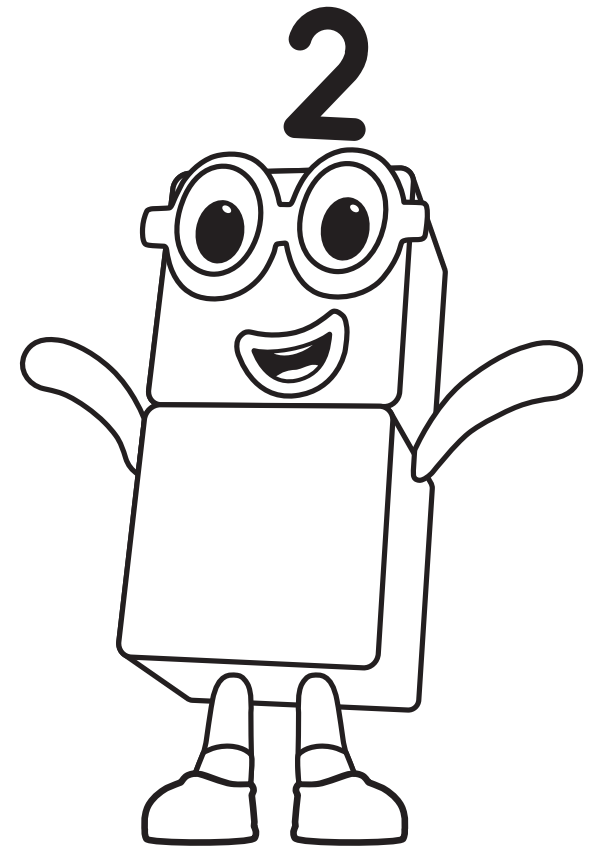
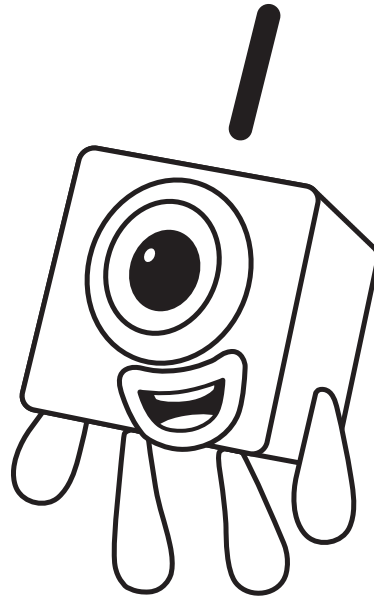
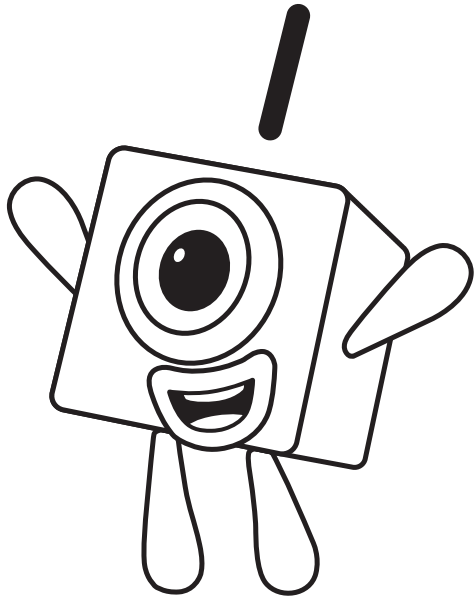

Number Explorer Missions



Find something that belongs in a pair



Touch your toes 2 times



Spot the number 2 two times when you are out



March around saying 1, 2, 1, 2!



Play Together

Make pairs. Cut out the pictures and ask your child to sort them into pairs. Then, play a memory game, placing all the pictures face down and taking turns to turn over two pictures. If they are the same, keep them, but if they don't match turn them over again. Can you find all the pairs?

For your next mission, find the episode 'Two'

Two

This mission belongs to

Print pages 1 and 2 double-sided and fold in half to make a booklet

2

I am Two!
How do you do?

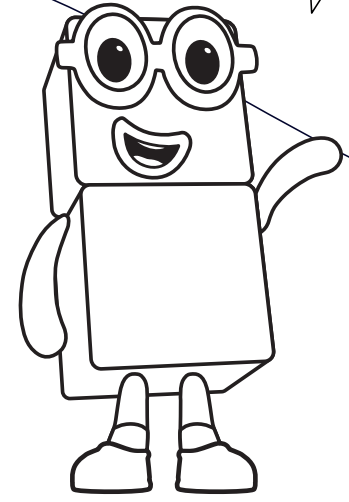

Fact File

2 is this many:



Numberblock Two has 2 blocks:

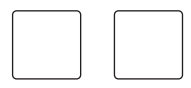

Two has 2 ones inside!

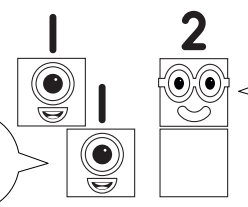

1+1=

Two



Numbers to 5



Meet Two



Two

2 2 Activities 2 2

2

Spot it!

Draw lines to match the pairs for Two.

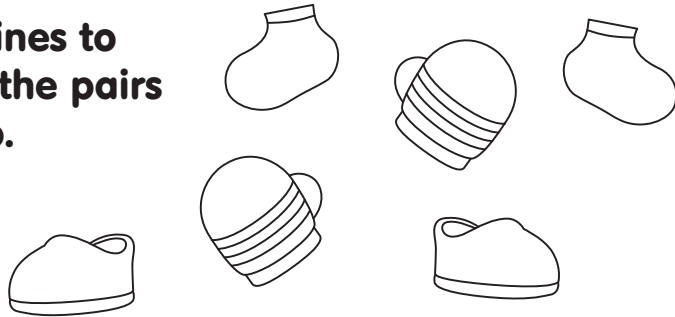

Touch and count

Count Two's eyes.

Count his arms.

Count his legs.

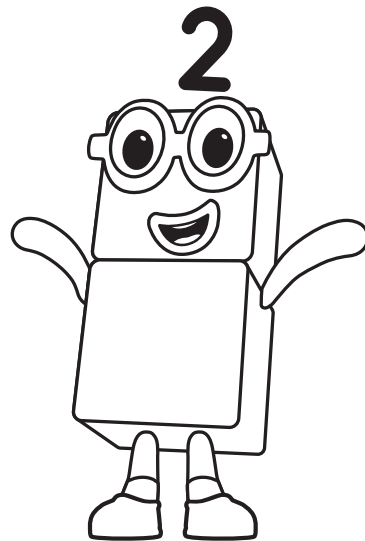

Match up

2

1

Draw lines to match One and Two to their Numberlings.

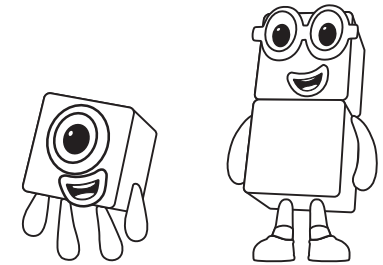

Which Numberblock can One and One make together? Circle them.

Who is it?



Say the answer!

How many ducks has Two found?

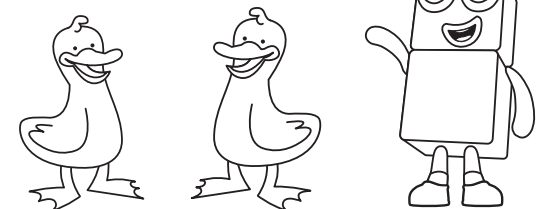

3

Make pairs

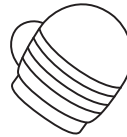
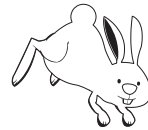
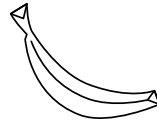
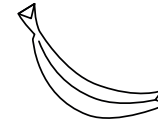
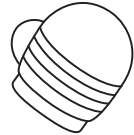

Number Explorer Missions



Hold up 2 fingers on one hand and three fingers on the other hand. Count them all together!



Find a friend. How many feet do you have altogether? How many each?



Find Four Shoes. How many sets of 2 feet fit in four shoes?



Play Together

Build the numbers! Cut out the blocks and use them to build the Numberblocks. Can your little learner build Numberblock 2? Can they figure out how to make Three? There are two ways to make Four and Five - can they find them?

For your next mission, find the episode 'The Terrible Twos'

The Whole of Me

This mission belongs to _____

Can you see smaller numbers of blocks inside Five?

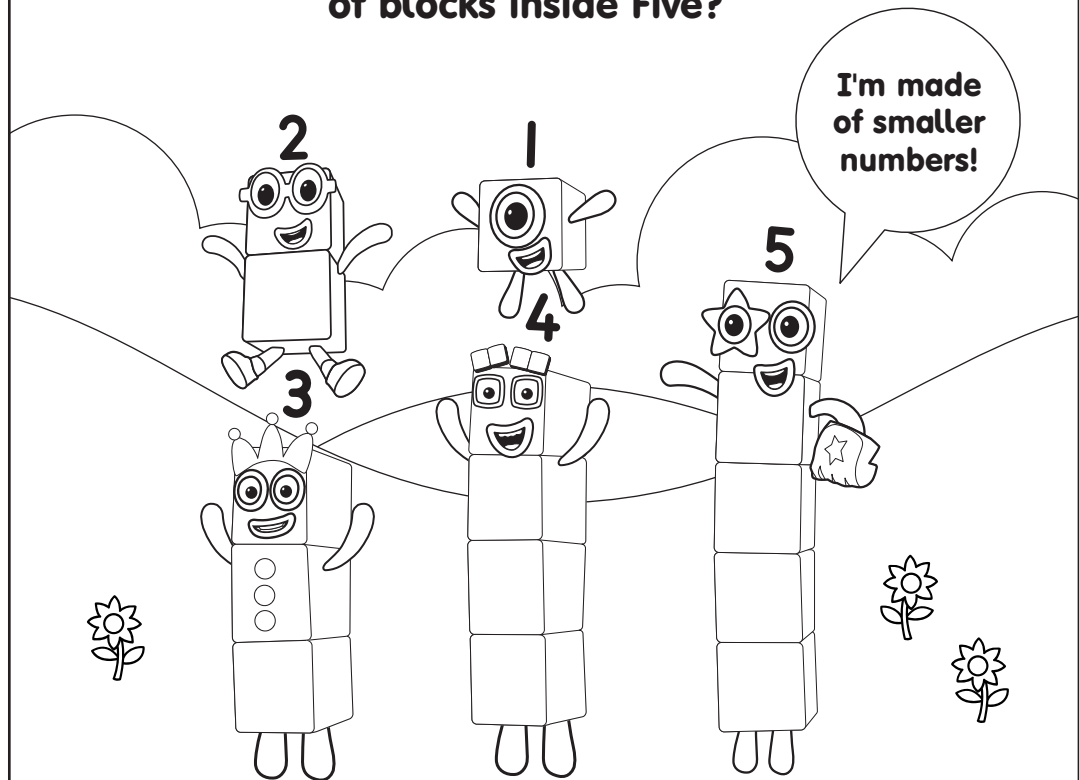

Print pages 1 and 2 double-sided and fold in half to make a booklet



Numbers to 5



Numbers inside other numbers



The Whole of Me

Activities

2

Who is it?

Which Numberblock is part of Two? Circle them.

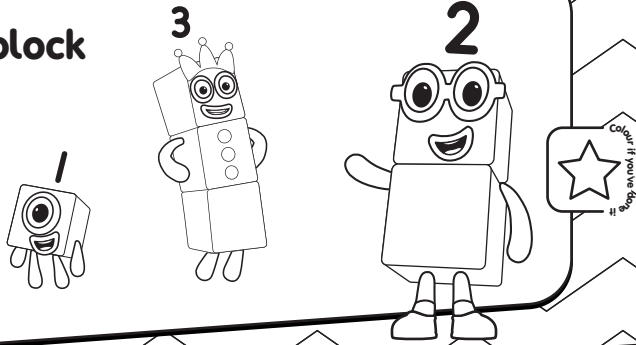

Which Numberblocks can fit inside Three? Tick them.

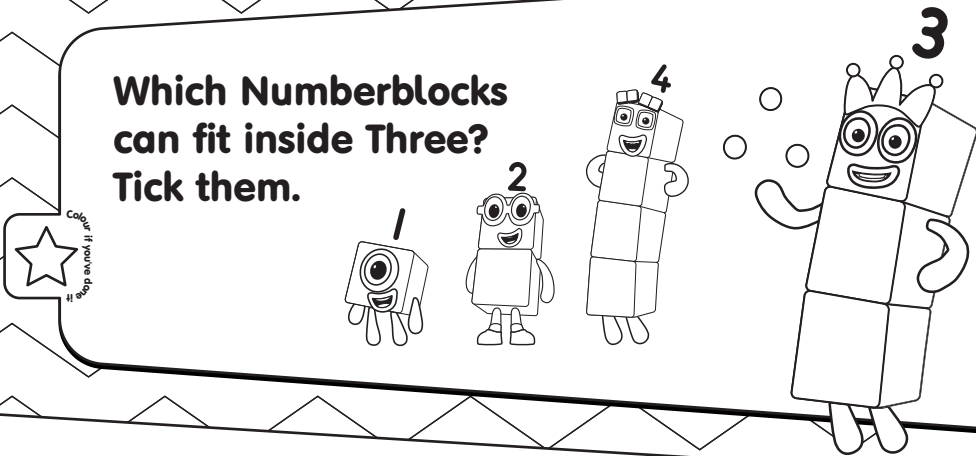

Which Numberblocks are part of Four? Colour them.

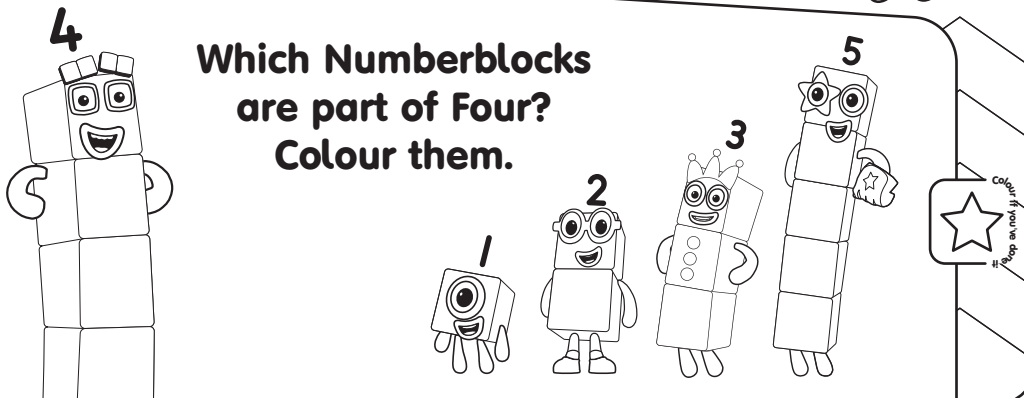

3

Which Numberblocks are part of Five? Draw arrows to point to them.

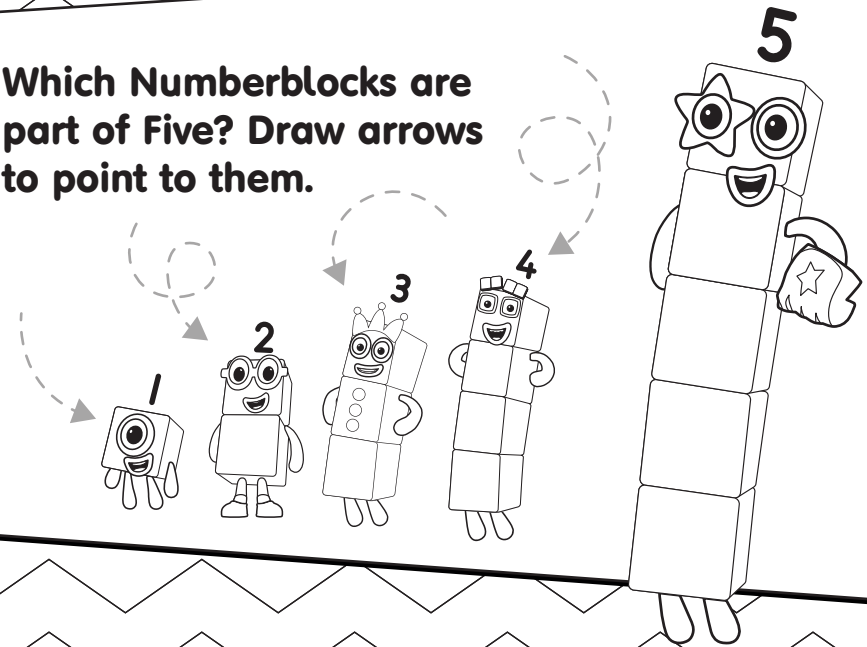

Which Numberblock is too small to have other numbers inside them? Finish drawing them.

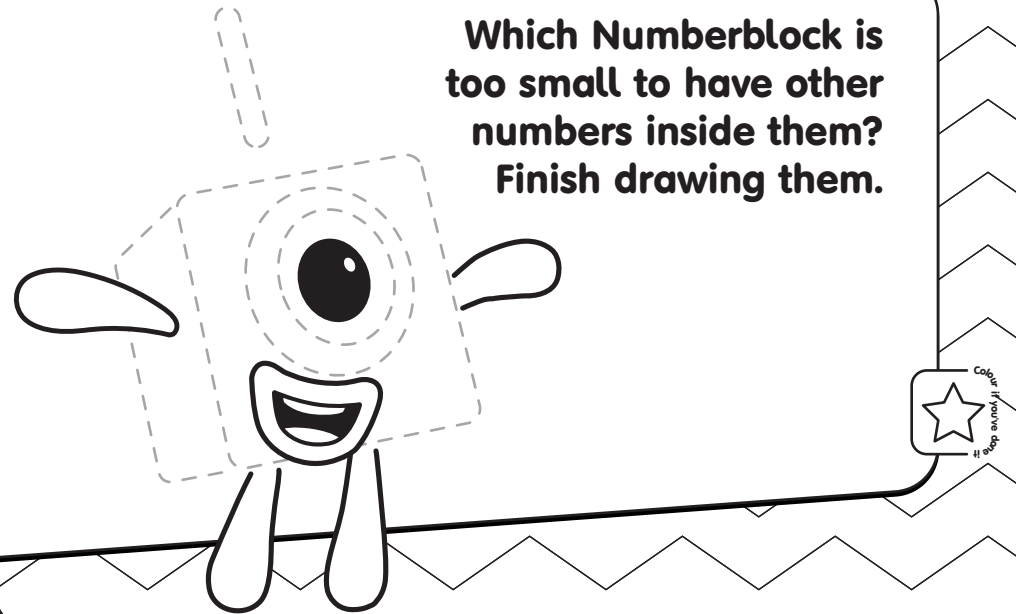

Build the numbers!

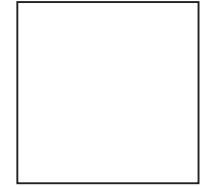
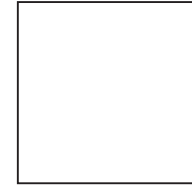
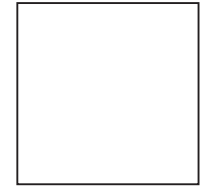
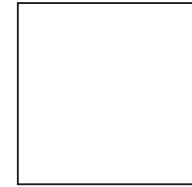
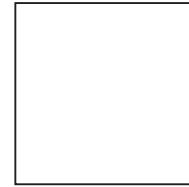
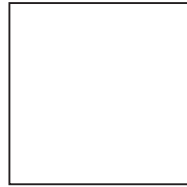
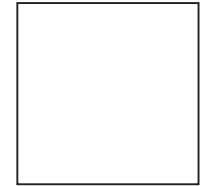
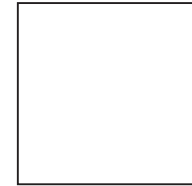
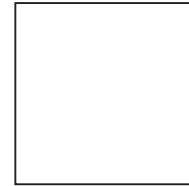
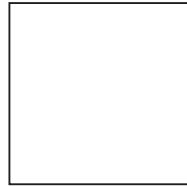
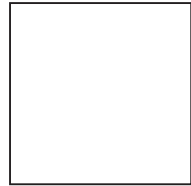
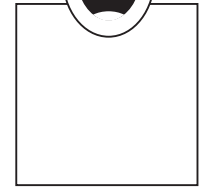
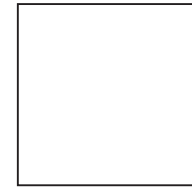
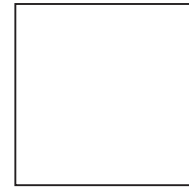
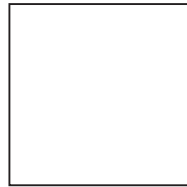
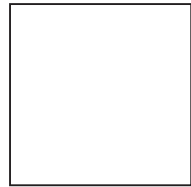
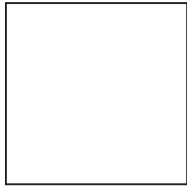
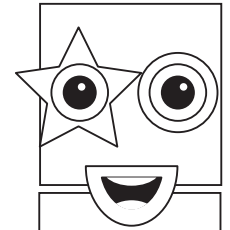
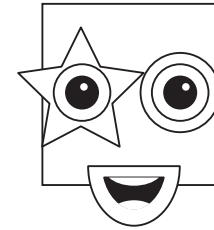
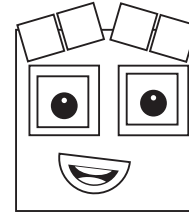
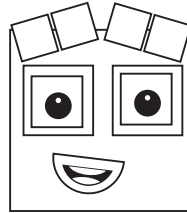
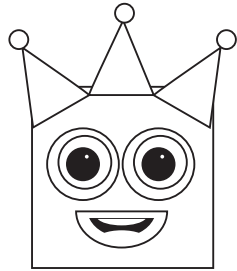
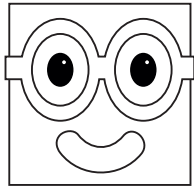
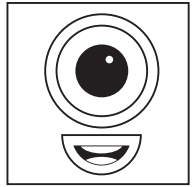

Number Explorer Missions



Can you stand on 1 leg?



Draw Numberblock One a house
with 1 window and 1 door



Spot 1 red thing



Find One's number on a sign



Play Together

Take one big spotting walk! Whether you're inside or outside, have fun counting to one - 1 dog! 1 door! 1 ball! 1 tree! Start together, then let your child take over.

Find the episode 'Another One' for your next mission!

One

This mission belongs to

Fact File

I is this many:



Numberblock One
has 1 block:



When you count,
you always start with 1:



I'm 1 of
a kind!

I'm One!
This is fun!

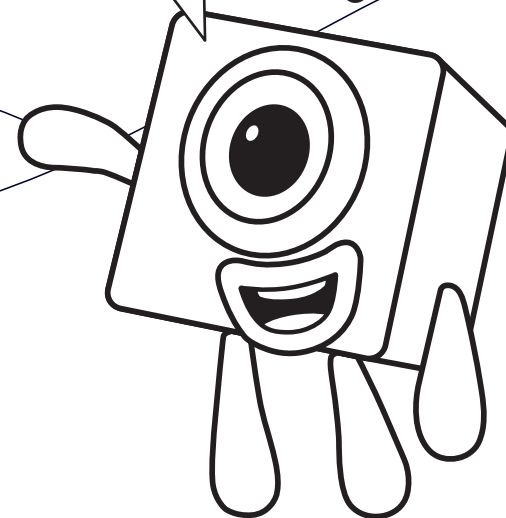

Numbers to 5



Meet One



One



Activities



Touch and count!

One's teddy has one big eye, like her. Can you point to it?

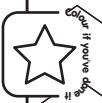
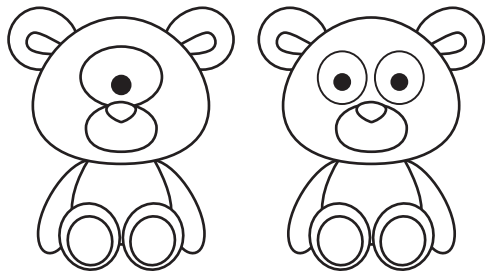

Shape fun

Copy One's numbering. It's 1 long line down



Say the answer

One!

How many birds can you see?

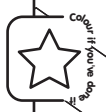
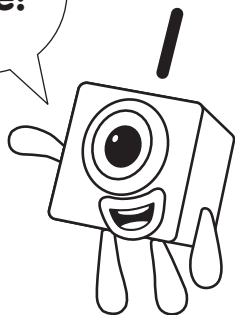

Touch and count!

Touch each thing and count to 1 as you do!

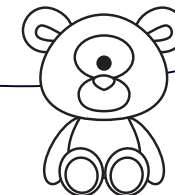
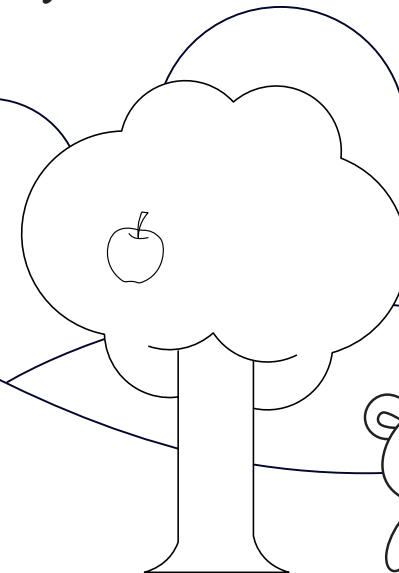

Spot it

Find 1 balloon somewhere on this double page.

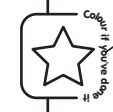
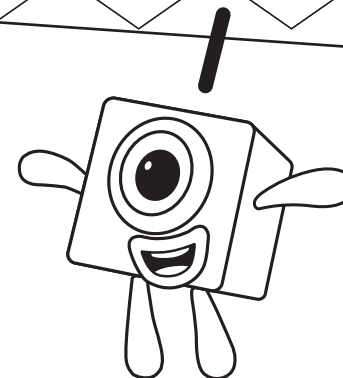

One Big Spotting Walk

Can you spot one of all of these things?
Colour in the star when you've spotted it.

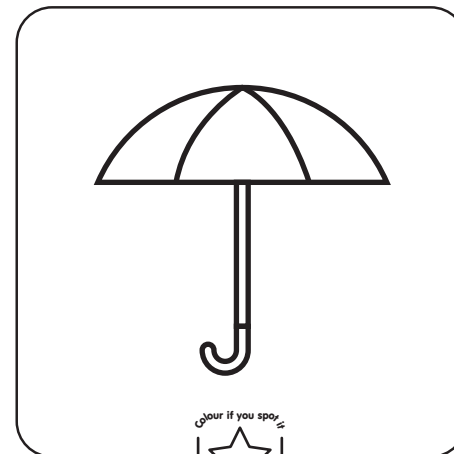
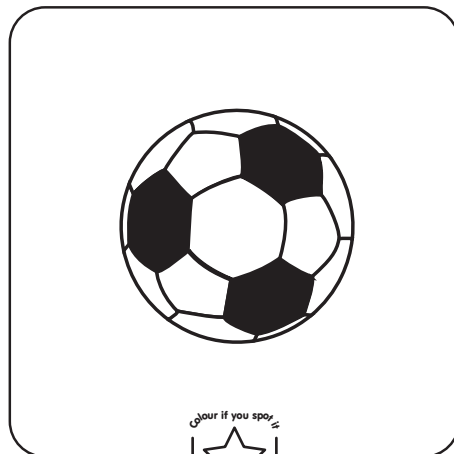
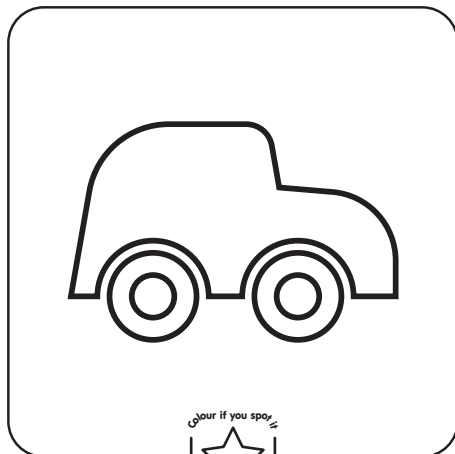
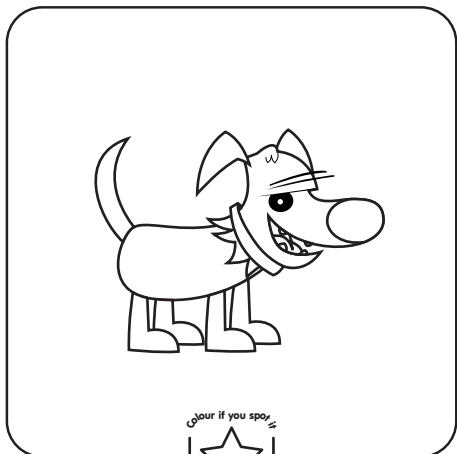
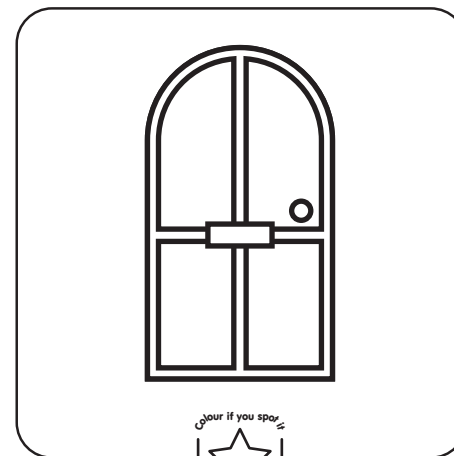
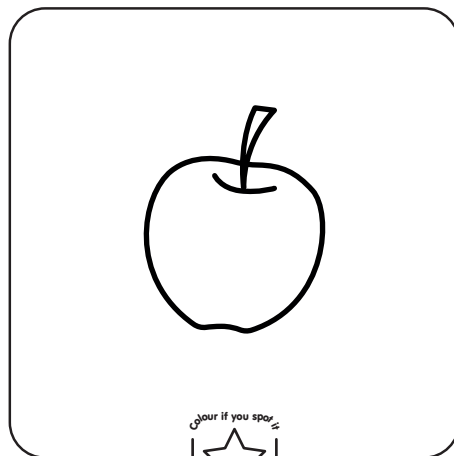
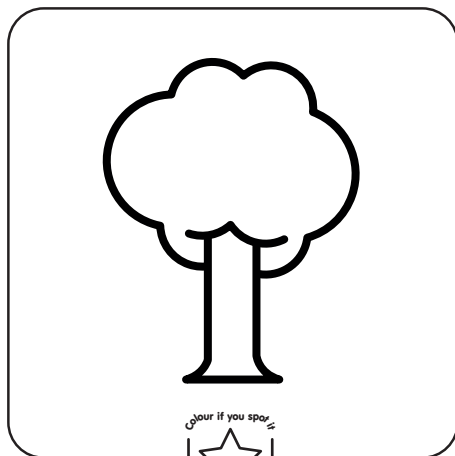
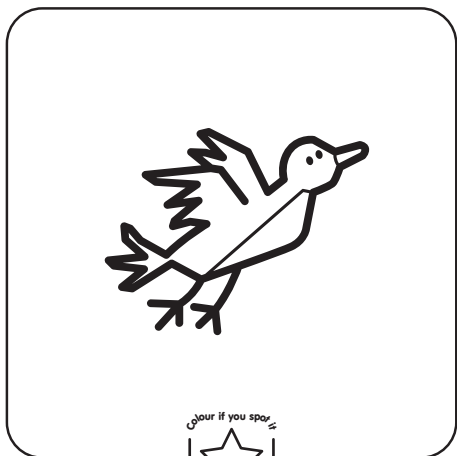

Number Explorer Missions



Find 5 small toys



Can you do 4 jumps?



Touch your nose 3 times



Spot 2 lorries



Play Together

Let's count! Cut out your Numberblocks and use them to help your little learner to count. Put them on the page to help sort out Three's number muddles.

Five's rules of counting

1. Count everything once.
2. Say the numbers in the right order.
3. The last number is how many!

For your next mission, find the episode 'Four'

How to Count!

This mission belongs to _____

Count out loud from One to Five!

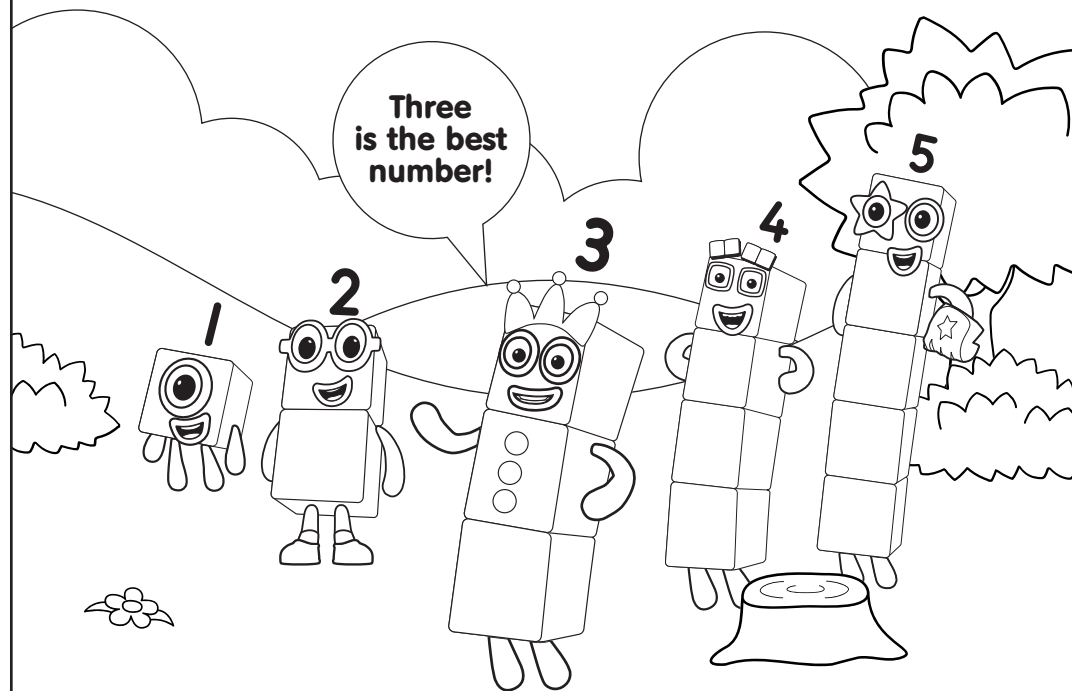

Numbers to 5



The rules of
counting



How to Count

Get ready

2

Find and cut out your Numberblocks, then use them to sort out Three's number muddles!

Spot it!

How many picnic baskets are there?

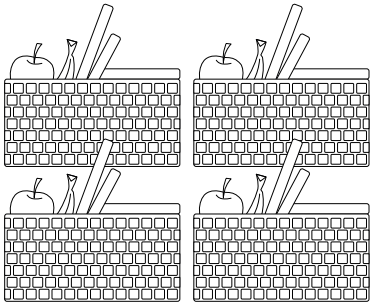

Put them here

Three?

3

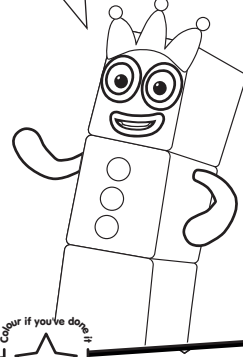

Who is it?

Count the Numberblocks. Which Numberblock shows how many we can see?

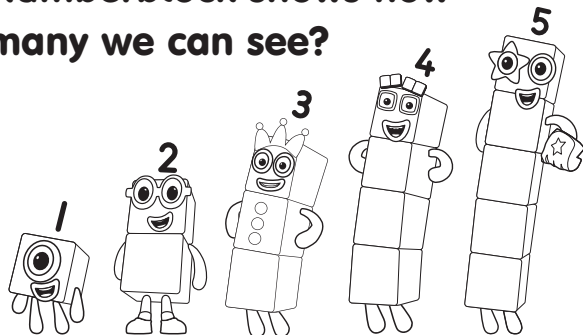

Put them here

Sort it out

3

Put your cut outs here to show Three the right order.

1, 2, 4, 3!

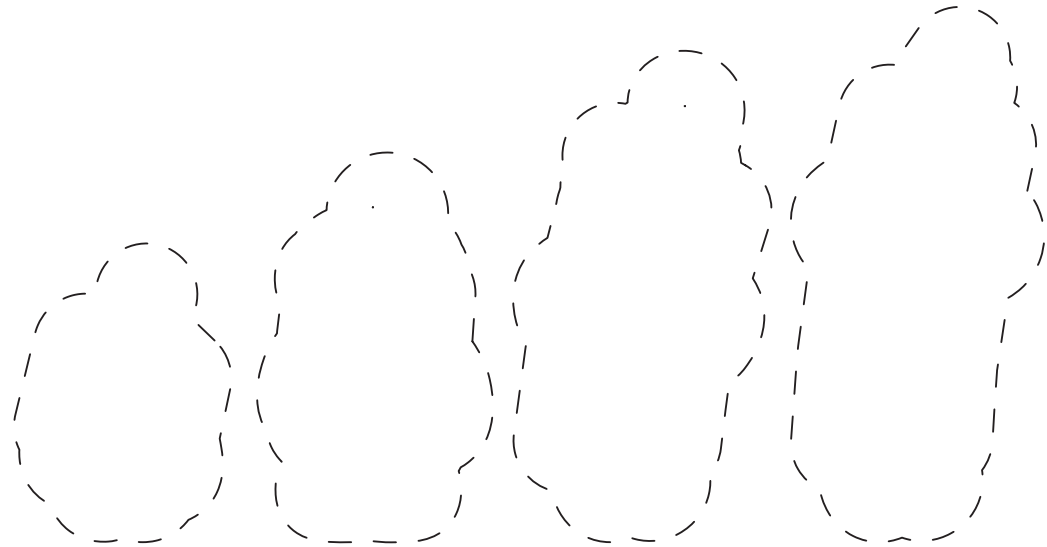
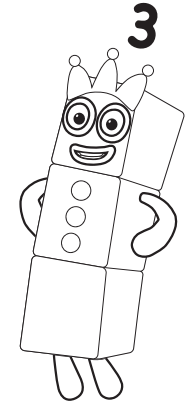
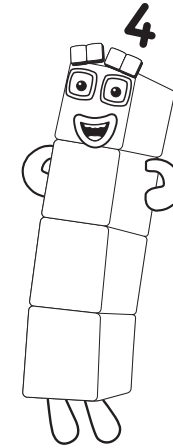
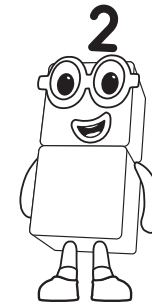

Let's count

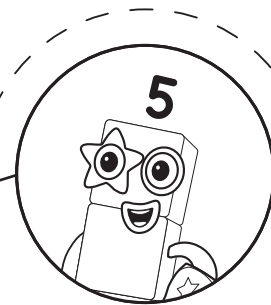
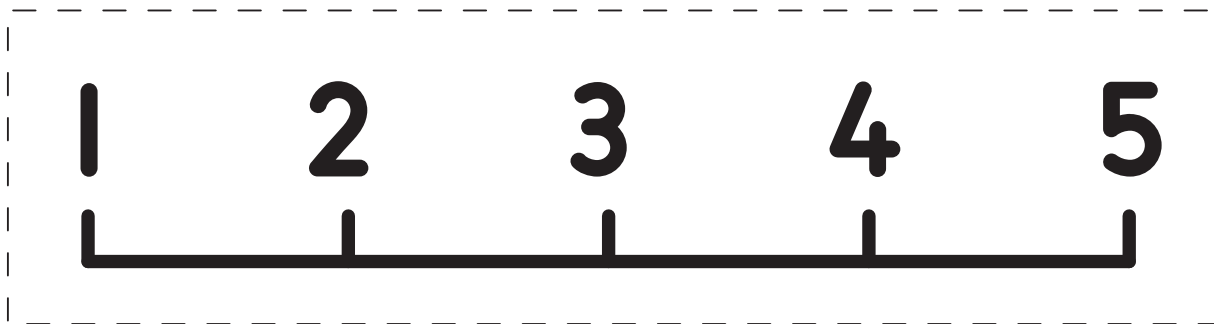
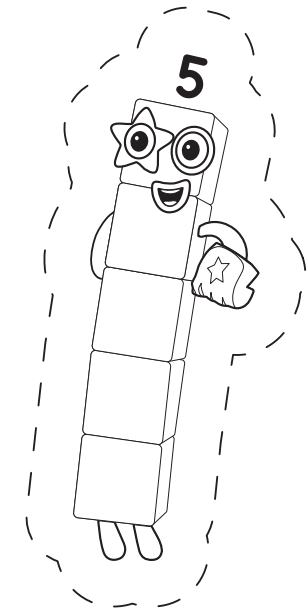
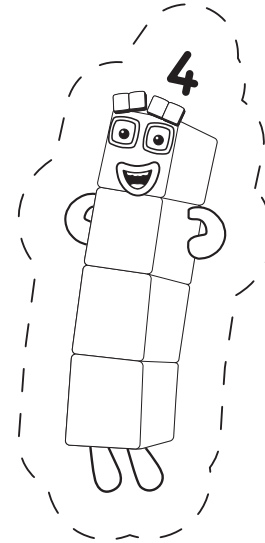
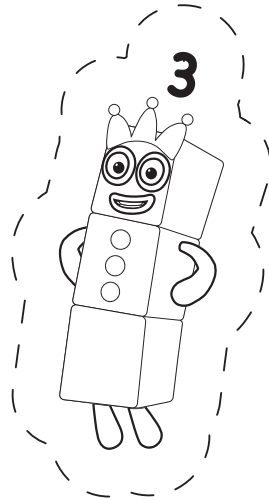
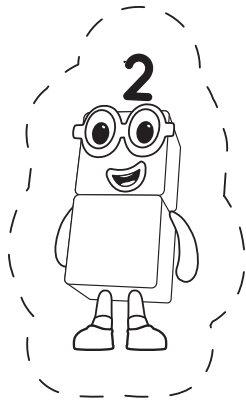

Five's rules of counting

1. Count everything once.
2. Say the numbers in the right order.
3. The last number is how many!

Number Explorer Missions



Can you spot any number shapes?



Look at the numbers on a dice!



Roll a dice and shout the number that's on top!



Play Together

Make number shapes! Colour squares in the printed grid to make Numberblock shapes with your child. Can they copy the shapes they see on this sheet? Challenge them to make a shape with 2 blocks, 4 blocks and so on. The only rule is that blocks must be joined by an edge, not a corner.

For your next mission, find the episode 'The Whole of Me'

Stampolines

This mission belongs to _____

How many blocks are in each of Three's shapes?

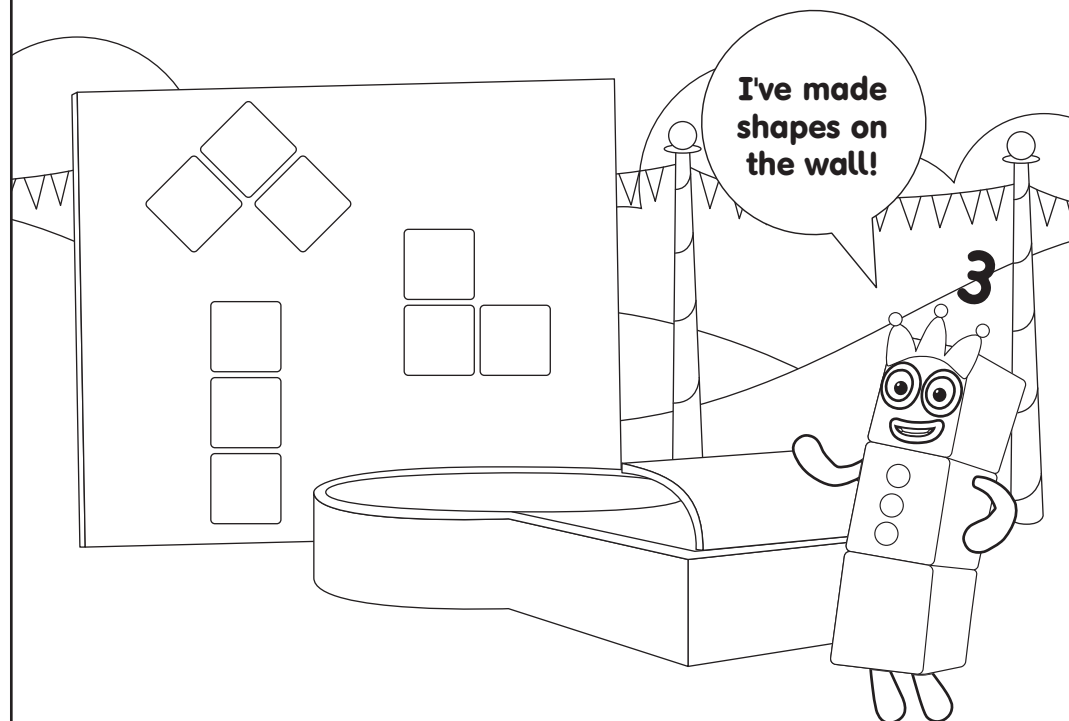

Numbers to 5



Recognise amounts without counting



Stampolines

Who is it?

Draw lines to match each Numberblock to their shape.



Which stamp was not made by Five? Guess, then count to see if you're right.



Touch and count!

How many shapes has Four made?

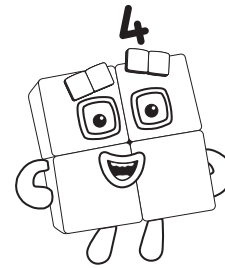

Count and colour!

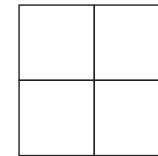
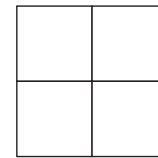
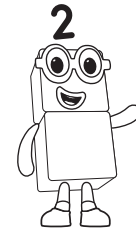

Colour two squares in each box to help Two make his stamps.



Circle it!

$$1 + 1 + 1 + 1 =$$

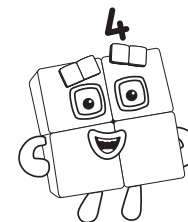

What number has One made? Circle the right Numberblock.



Make Number Shapes

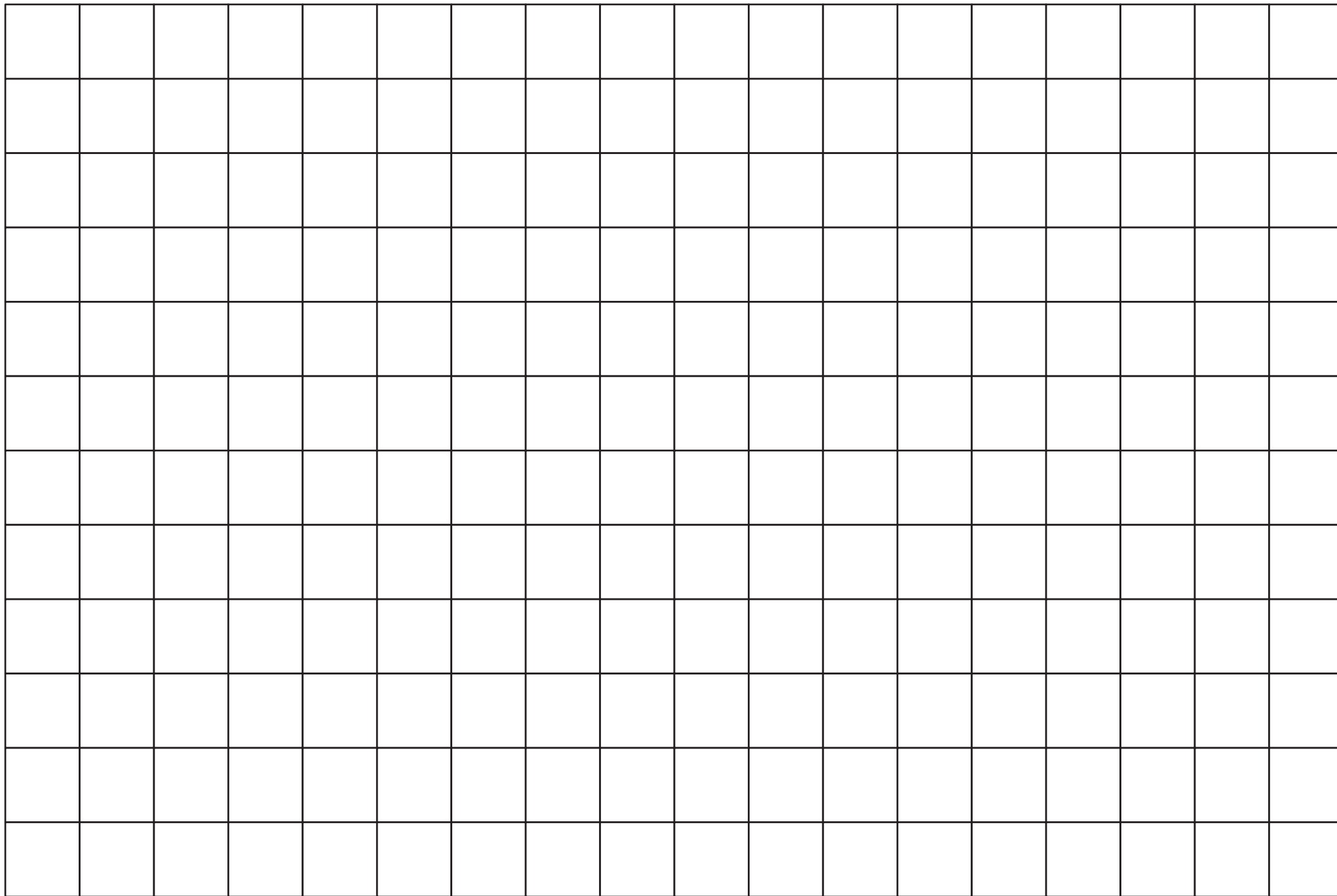

Number Explorer Missions



Hold up 4 fingers on one hand. How many fingers are folded down?



Fold down another finger. How many are left?



Keep going until only one is left.



Play Together

Munchy maths! Why not practice adding and taking away with small snacks. Start with 1 and add one more, working out how many there are each time, until there are five. Then the really fun part - let your little one take one away each time by munching it. How many are left?

For your next mission, find the episode 'Holes'

Holes

This mission belongs to

5

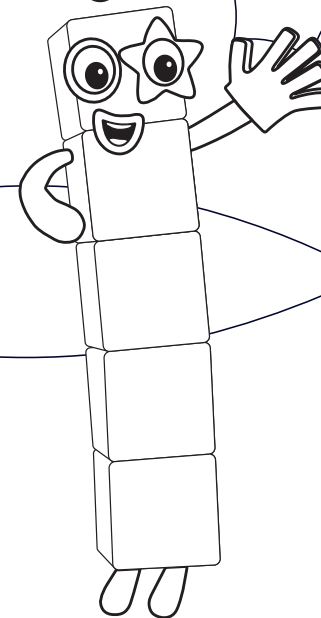

Oh look!
A hole, so big
and round!



Numbers to 5



Add and subtract
away to 5



Holes

Who is it?

2

Use your cut-outs to answer with the right Numberblock.

5 - 1 =

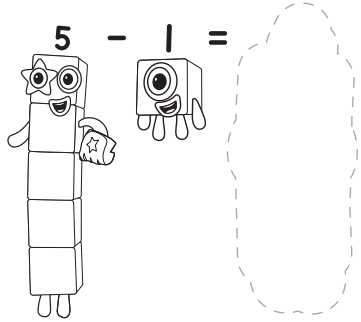

4 - 1 =

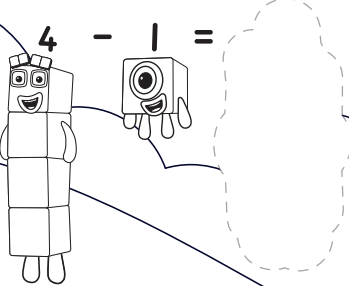

3 - 1 =

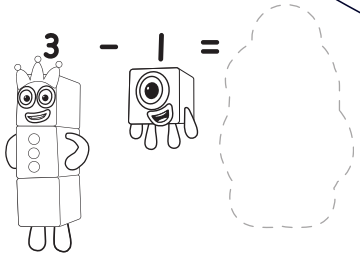

2 - 1 =

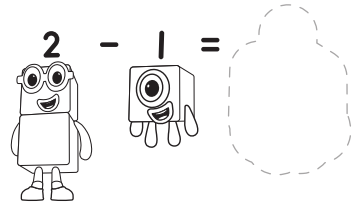

3

4 + 1 =

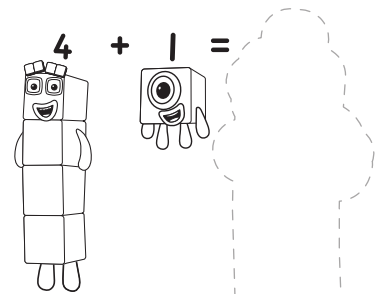

3 + 1 =

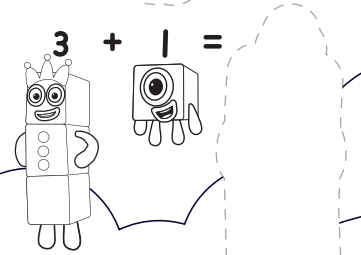

2 + 1 =

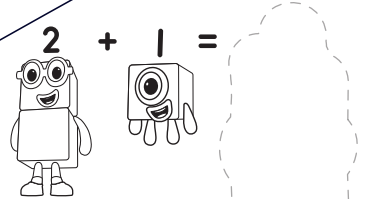

1 + 1 =

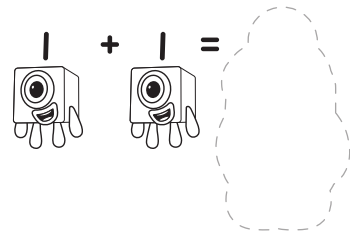

Get ready!

Cut out these Numberblocks and use them to give your answers.

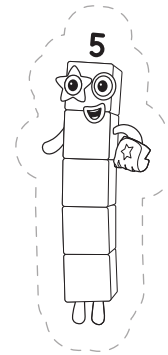
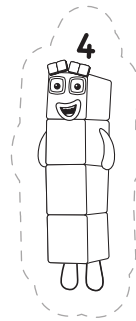
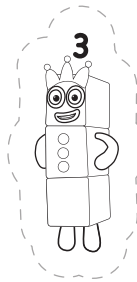
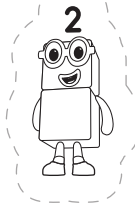
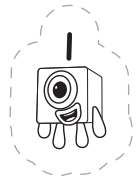
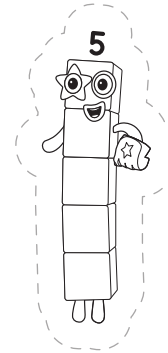
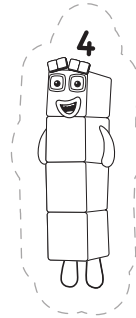
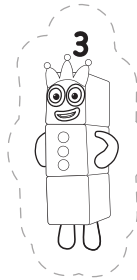
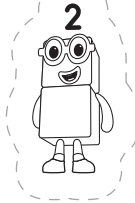
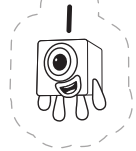

Number Explorer Missions



Hold up 3 fingers. How many more do you need to make 5?



Climb up 1 step. How many more do you need to make 5?

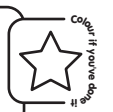

Make a pile of 5 toys. How many different ways can you split your pile?



Play Together

Numberblock hide and seek! Cut out your Numberblocks and play a hide and seek game with them. You could hide one number from the line up and ask your child to spot who is missing, or experiment with which Numberblocks other Numberblocks can hide behind - for example everyone can hide behind Five because she's the biggest.

For your next mission, find the episode 'Once Upon a Time'

Hide and Seek

This mission belongs to _____

Let's play hide and seek!

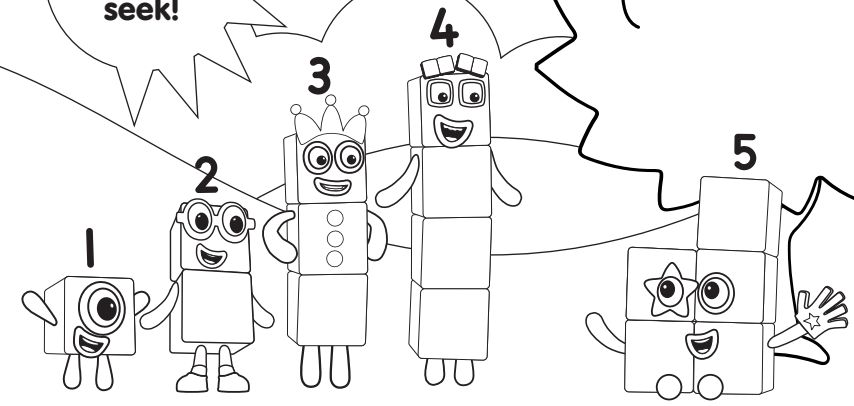

Print pages 1 and 2 double-sided and fold in half to make a booklet



Numbers to 5



Ways to make 5





Hide and Seek



Who is it?

2

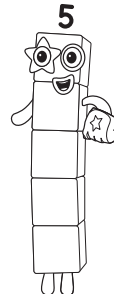

The Numberblocks are finding ways to make Five! Use your cut outs to fill in the gaps.

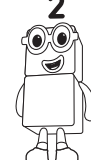

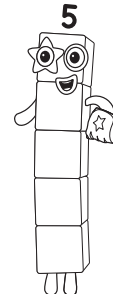
 $?\ +\ 4\ =\ 5$

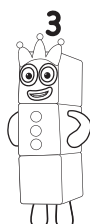

 $2\ +\ ?\ =\ 5$

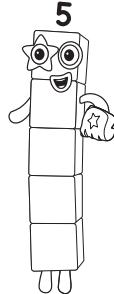

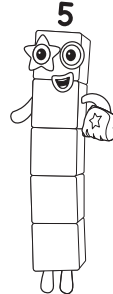
 $3\ +\ ?\ =\ 5$

 $5\ -\ ?\ =\ 4$

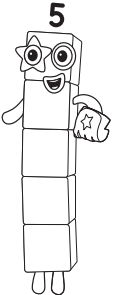
 $5\ -\ 2\ =\ ?$



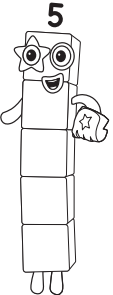

 $5\ -\ ?\ =\ 2$

Spot it!

3

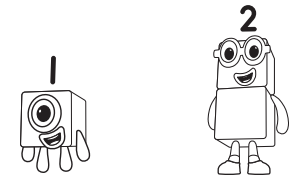
Which Numberblock can Two hide behind?
Circle them.



Which Numberblock can Four hide behind?

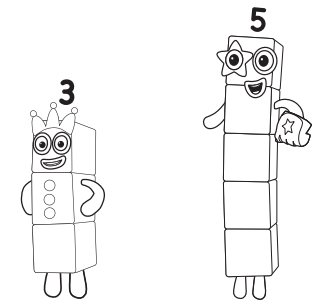

Which Numberblock can Three hide behind?

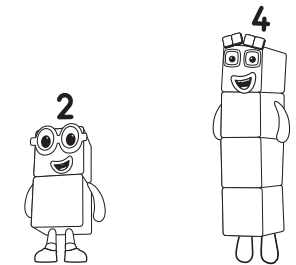

Say it! Are the numberblocks in the right order?

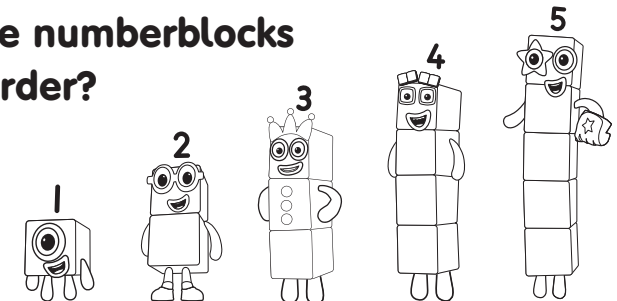

Let's count



1

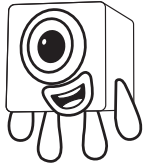

2

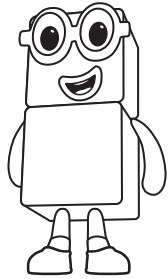

3

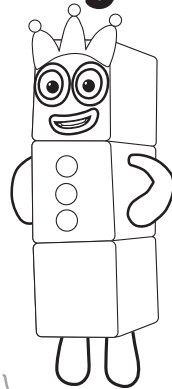

4

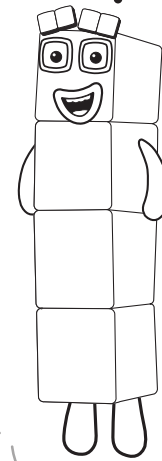

5

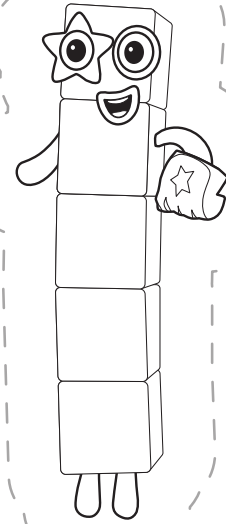

Number Explorer Missions



Find 1 red apple and 1 green apple. How many apples are there altogether?



Find 2 pairs of socks. How many socks altogether?



When you see a 2, shout 'Terrible Twos!'



Find 2 green leaves and 1 brown leaf. How many leaves are there altogether?



Play Together

Go on a twos hunt! Help your little learner to spot twos within bigger numbers. You could notice that a car has 4 wheels, which is also 2 sets of 2. A four pack of yogurt, legs on a table, fruit in a fruit bowl, prongs on a fork - how many can you find together?

For your next mission, find the episode 'Holes'

The Terrible Twos

This mission belongs to _____

Which Numberblock can the Terrible Twos make together?

We're the Terrible Twos!

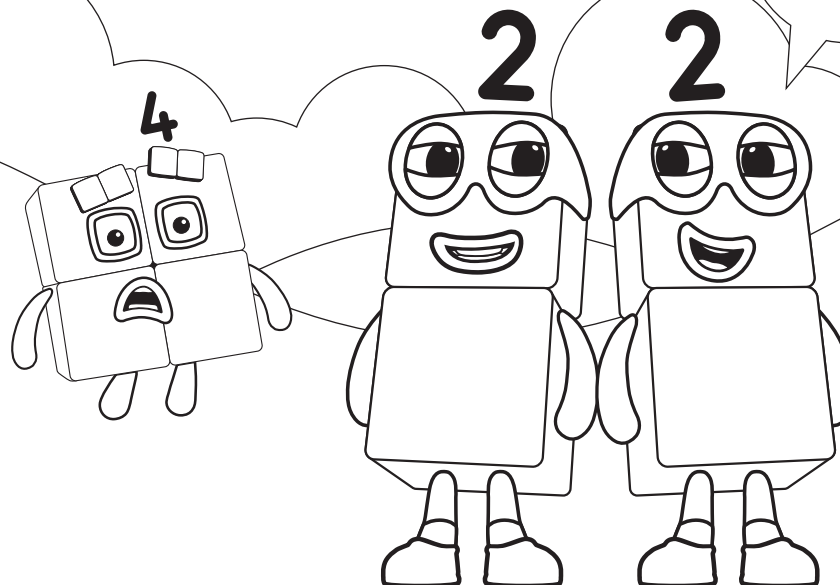

Numbers to 5



Counting in
1s and 2s



The Terrible Twos

Activities

2

How many ones?

Draw lines to match each Numberblock with the number of Ones they are made of.

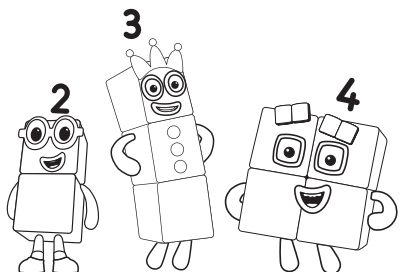
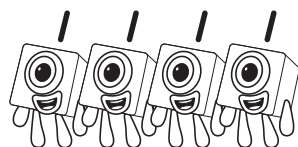
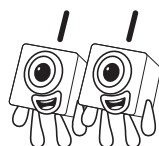
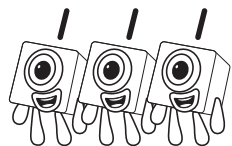

Find the 2s!

Circle the Numberblocks that have 2s inside them.

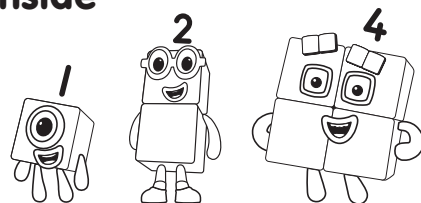

Spot it!

Can you find 2 Terrible Twos hiding on this page?



Who is it?

Tick the right Numberblock.

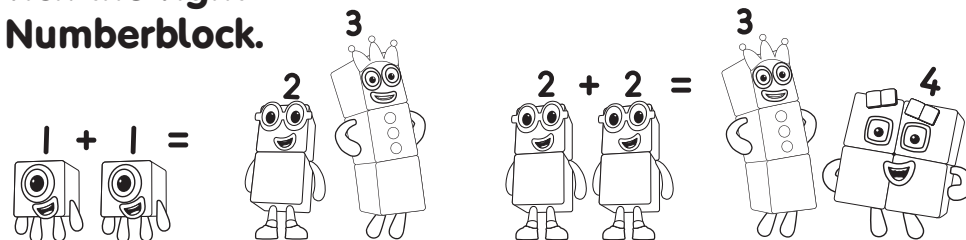

Draw the blocks!

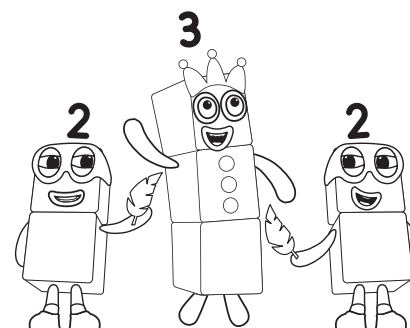

Uh oh! The Terrible Twos are tickling Three. How many Ones will she split into? Can you draw them?



Count and draw!

How many 2 blocks can you see in Five? Draw around them.

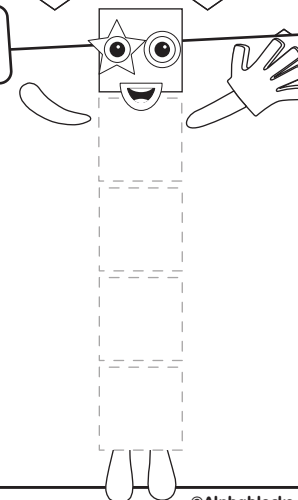

3

Number Explorer Missions



What numbers can you spot when you're out?



Can you find another number that's greater?



Can you find another number that's less?



Play Together

Blockzee! Cut out the Blockzillas and Numberblocks and play a sorting game. Place one Numberblock to the left and Blockzilla in the middle. Can your child find a Numberblock that is greater than (or less than) the first? Can they find one that equals the first? For a tricky challenge, place 2 Numberblocks and ask your child to choose the right Blockzilla to put between them.

For your next mission, find the episode 'The Numberblocks Express'

Blockzilla

This mission belongs to _____

Which is the biggest Numberblock?
Point to them.

It's
Blockzee!

5

I like BIG
numbers!

Fact File

This block monster always looks for bigger numbers. Her mouth shows which number is bigger or smaller.

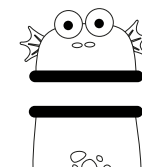
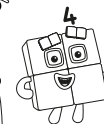
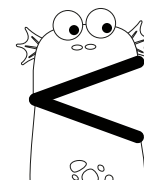

She can show when numbers are the same too.



Numbers to 5



Greater than,
less than



Blockzilla

Who is it?

2

Tick the biggest number for Blockzee.

2 is less than...?

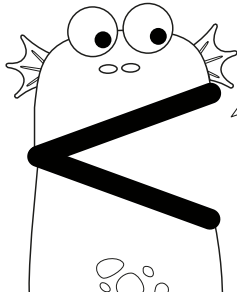
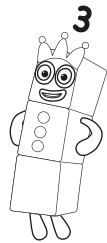
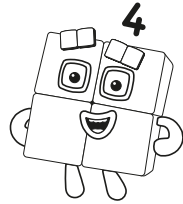
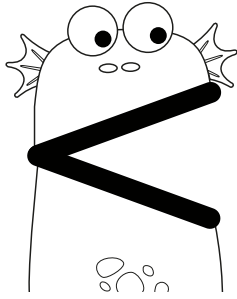
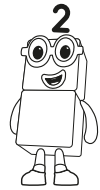

3 is less than...?

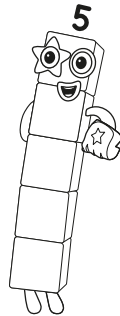
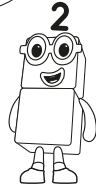

Match up!

Draw lines to match the numbers that are the same.

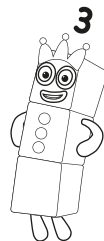
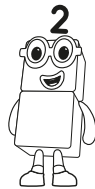
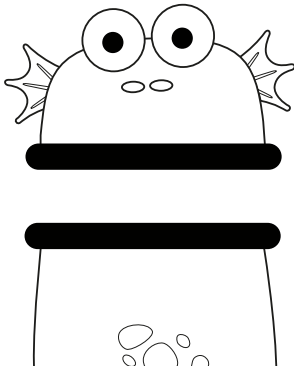
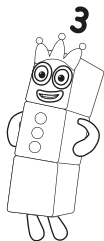
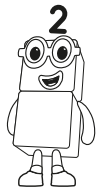

Who is it?

3

Circle the biggest number for Blockzee.

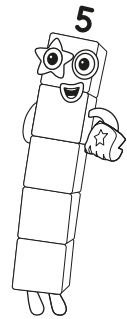
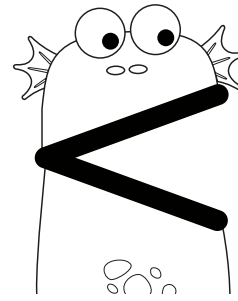
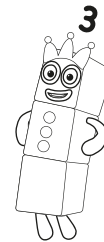
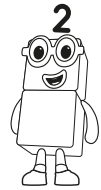
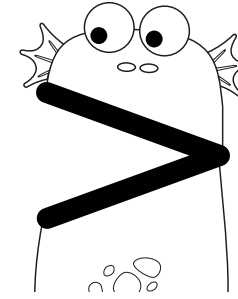
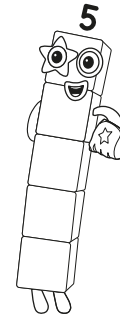

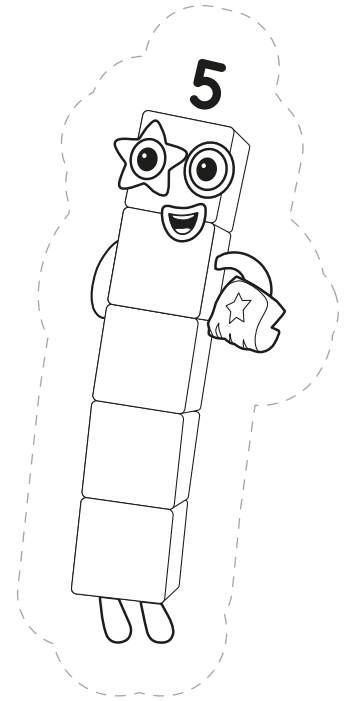
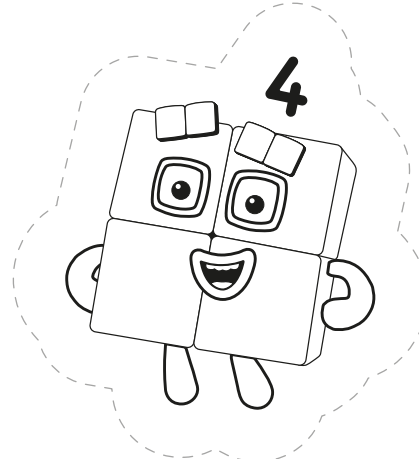
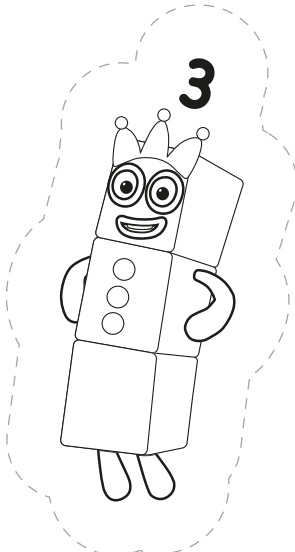
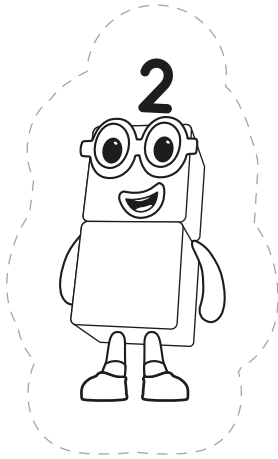
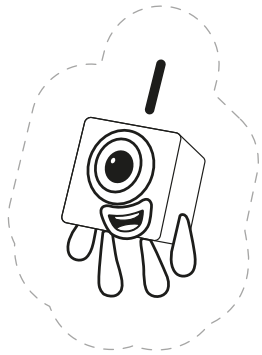
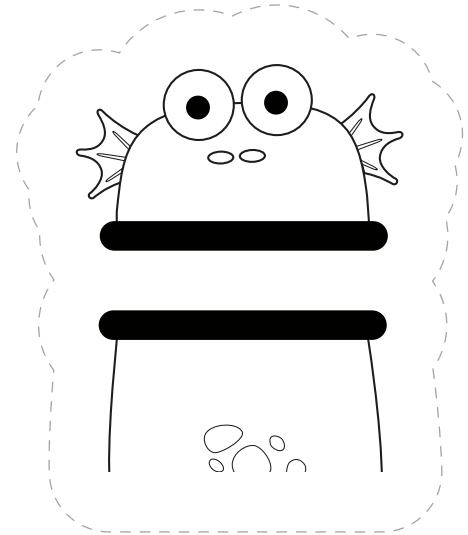
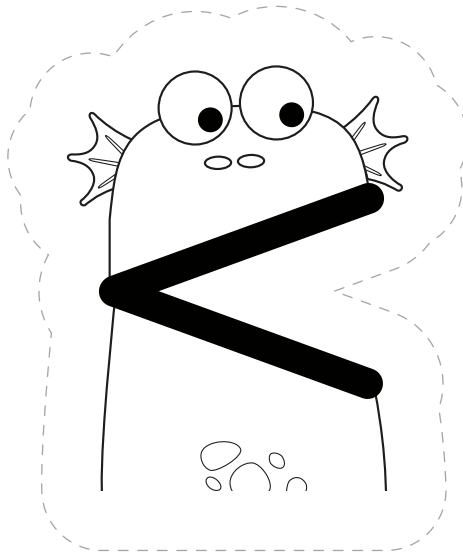
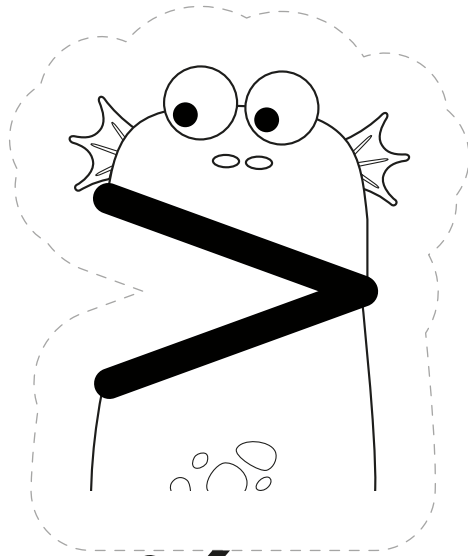

Number Explorer Missions



Count the fingers on one hand!



Now count the other hand!



Can you count the toes on one foot?



What about the other foot?



Play Together

Line them up! Cut out Numberblocks One to Five. Can your little learner put them in order? Can they figure out who to move if you put them in the wrong order? Hide a Numberblock and see if they can figure out who is missing. Can they order the Numberblocks from Five down to One too?

For your next mission, find the episode 'How to Count'

Off We Go!

This mission belongs to _____

Who's off on an adventure? Touch them and say their names!

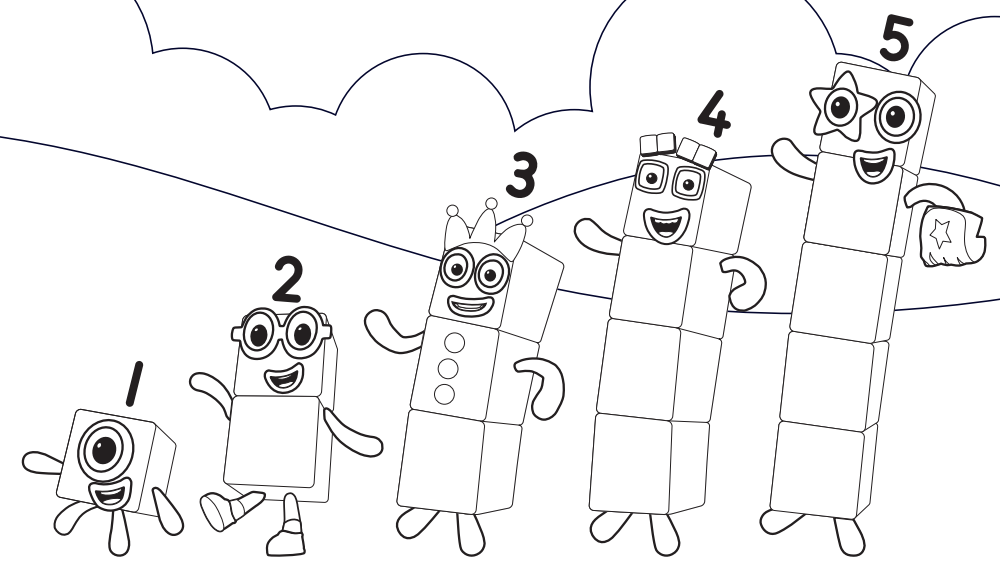

Numbers to 5



Ordering numbers



Off We Go!

Print pages 1 and 2 double-sided and fold in half to make a booklet

Who is it?

2

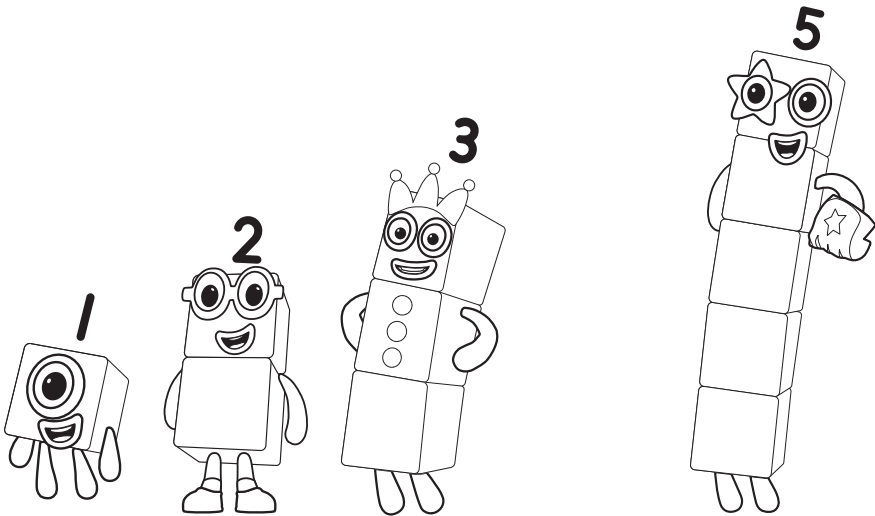
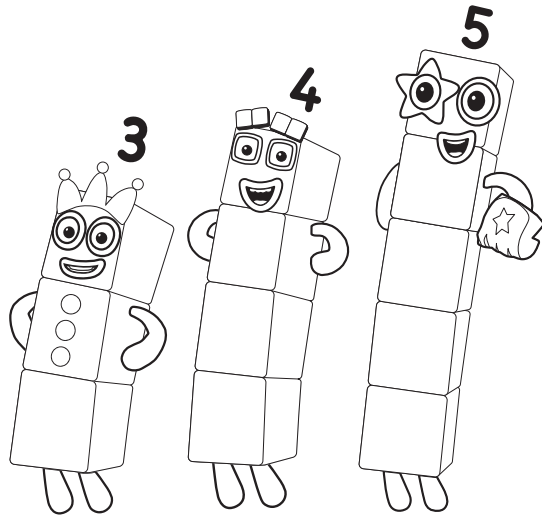
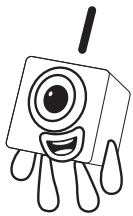

Someone is missing in each row!
Can you use your cut outs to add them?

3

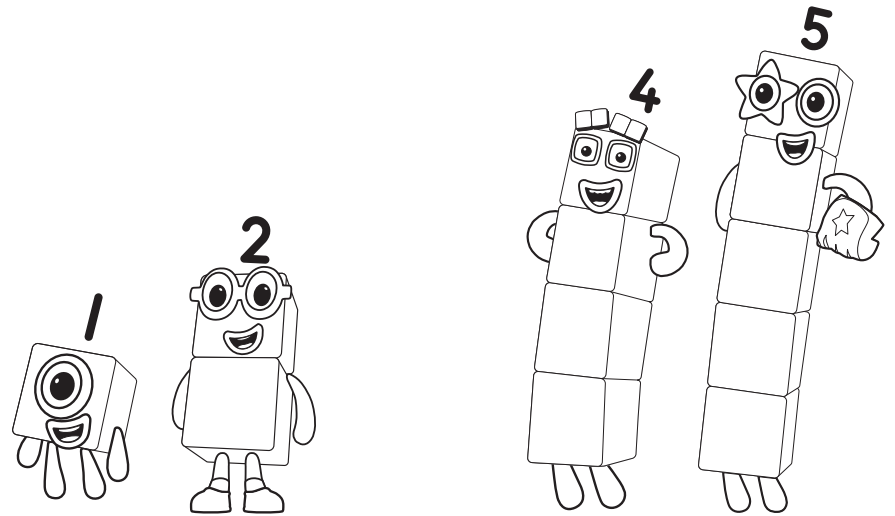
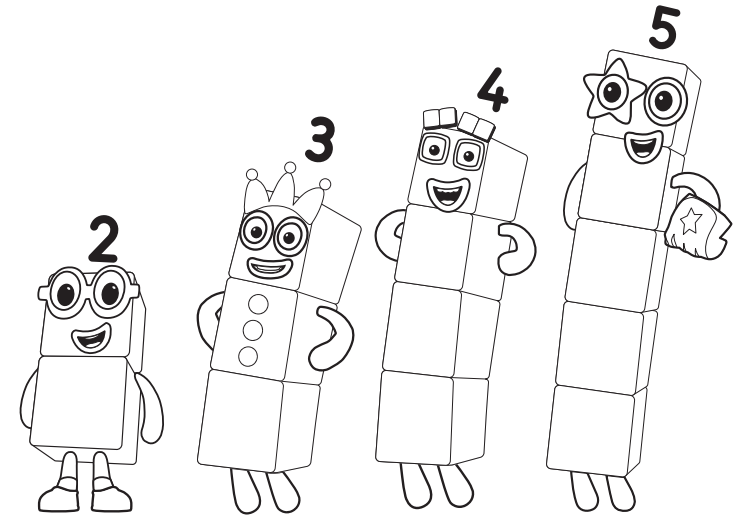

Line them up!

